



DVB-T/T2

Fundamentals

Presentation to DVB Workshop
KL March 2012

John Bigeni
bigeni@dvb.org

Part 1 Agenda

- **Background**
- **COFDM**
- **DVB-T2 Technologies**
- **Performance of DVB-T2 relative to other standards**

Terrestrial Propagation Realities

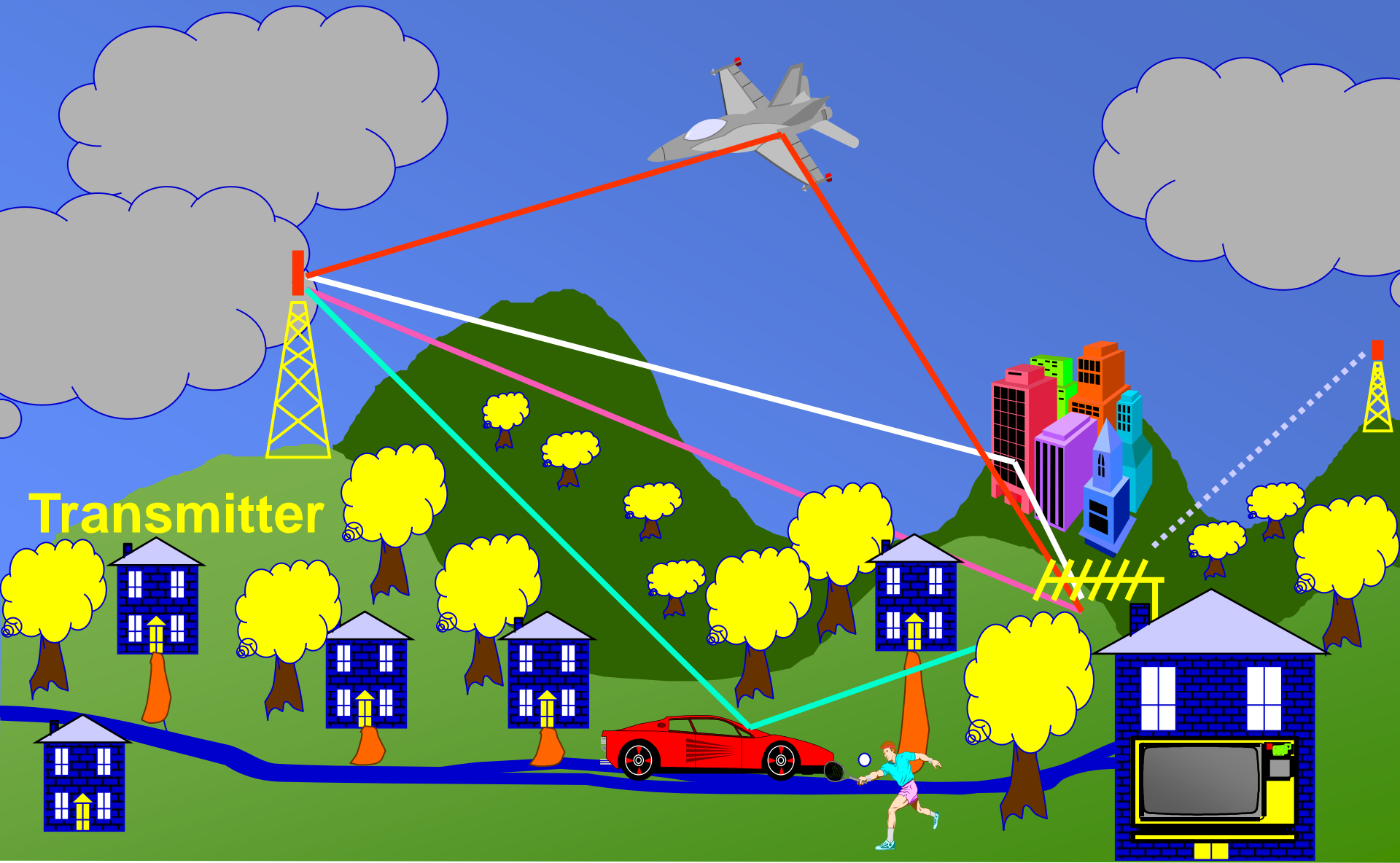

COFDM - What does it mean!

-
- Real life terrestrial delivery is complex.
 - Received signal is a dynamic combination of signals arriving at varying delays.
 - Resulting channel spectrum is far less than ideal
 - Solution ;
 - Transmitted Data spread over large number of closely spaced frequency sub-bands.
 - Data protected before transmission
 - Coded Frequency Division Multiplex - **COFDM**

Terrestrial propagation - channel response

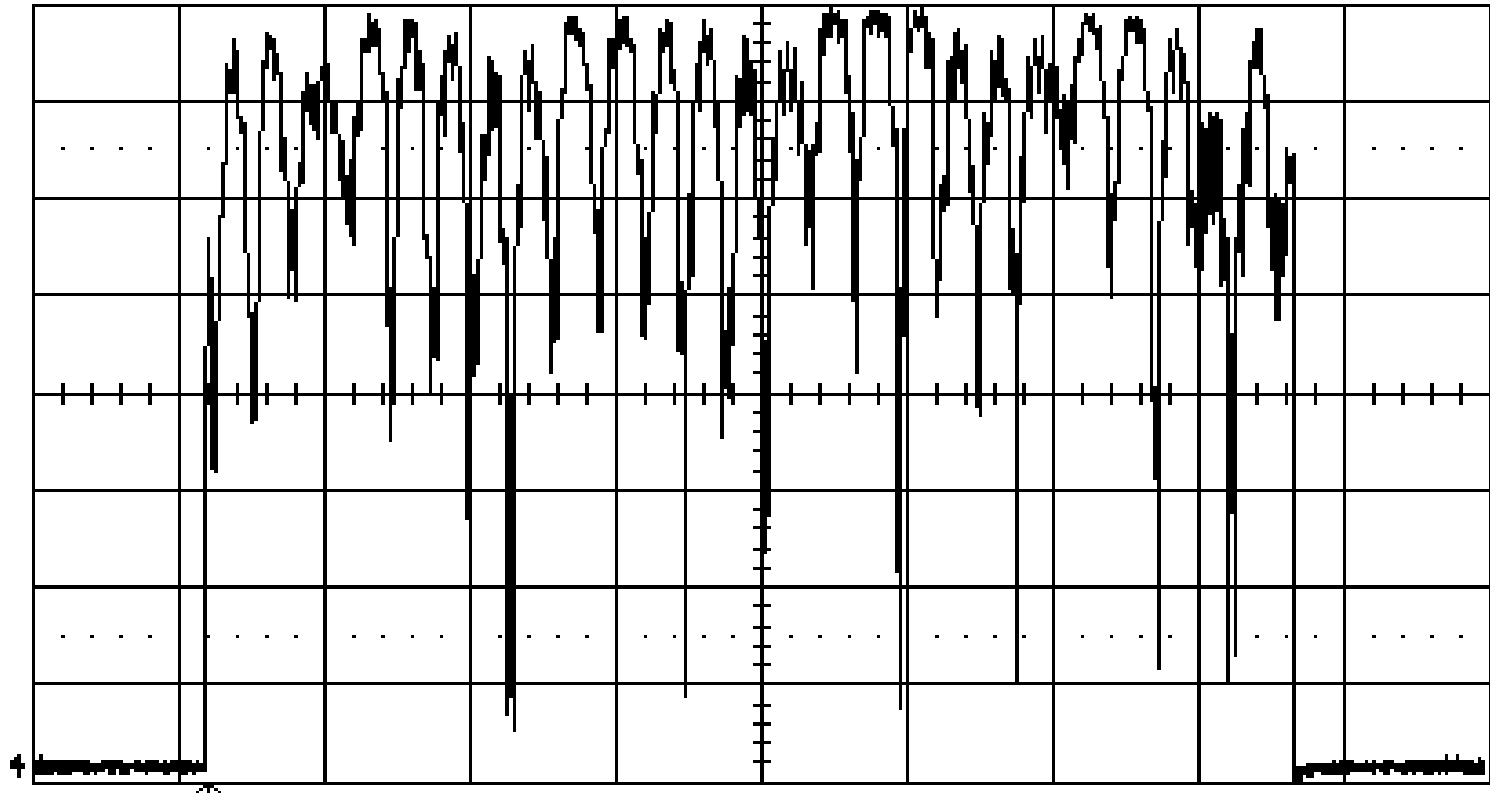

COFDM is the solution to cope with selective and time-variant frequency fading.

Spectrum of COFDM

**Coded
Orthogonal
Frequency
Division
Multiplex**

8MHz Carrier Spacing
2k Mode 4.47 kHz
8k Mode 1.12 kHz

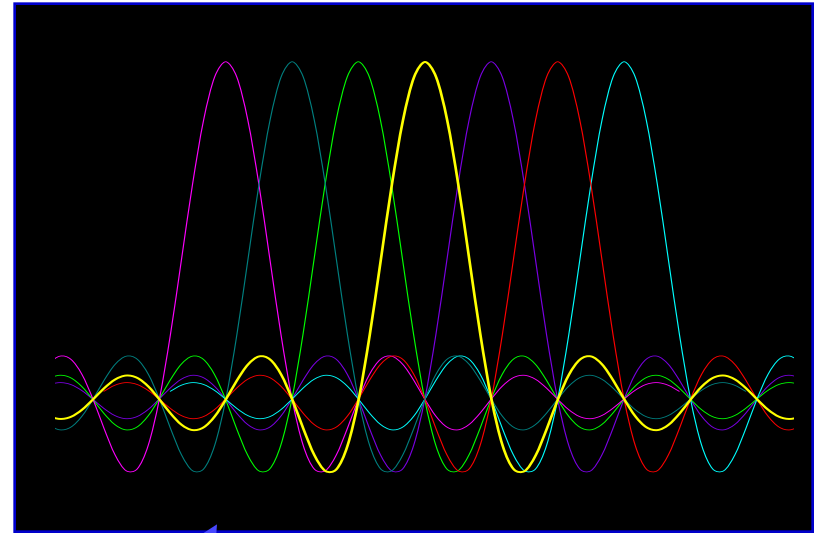

**Almost
Rectangular
Shape**

1705 or 6817 Carriers
(2k Mode) (8k Mode)

7.61 MHz in 8 MHz Channel

COFDM : HOW ?

- 1 - Organize time & frequency partitions in the RF channel

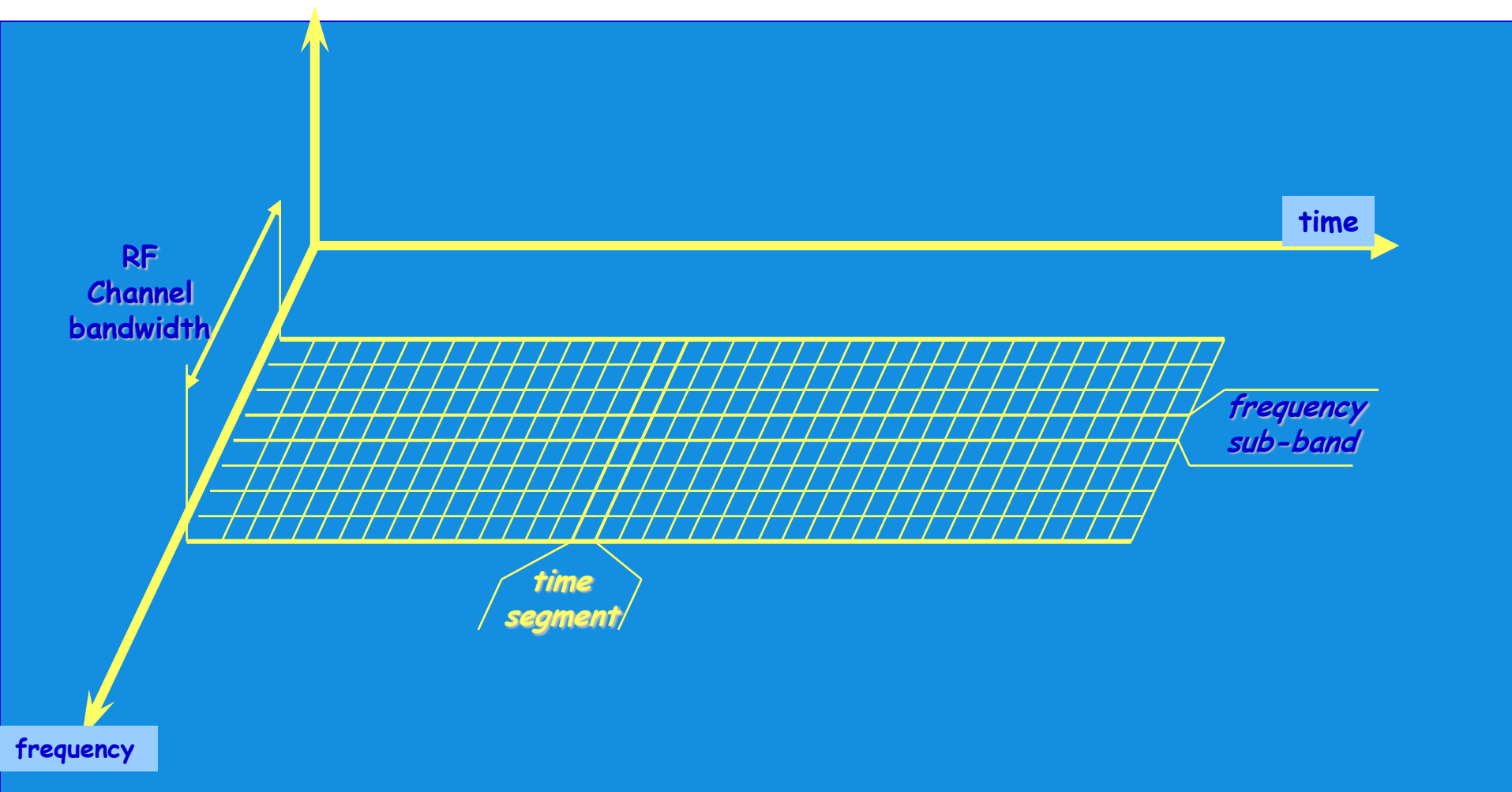

Channel characteristics are based on "time vs frequency" cells

COFDM : HOW ?

- 2 - Spread sub-carriers over “time vs frequency” cells

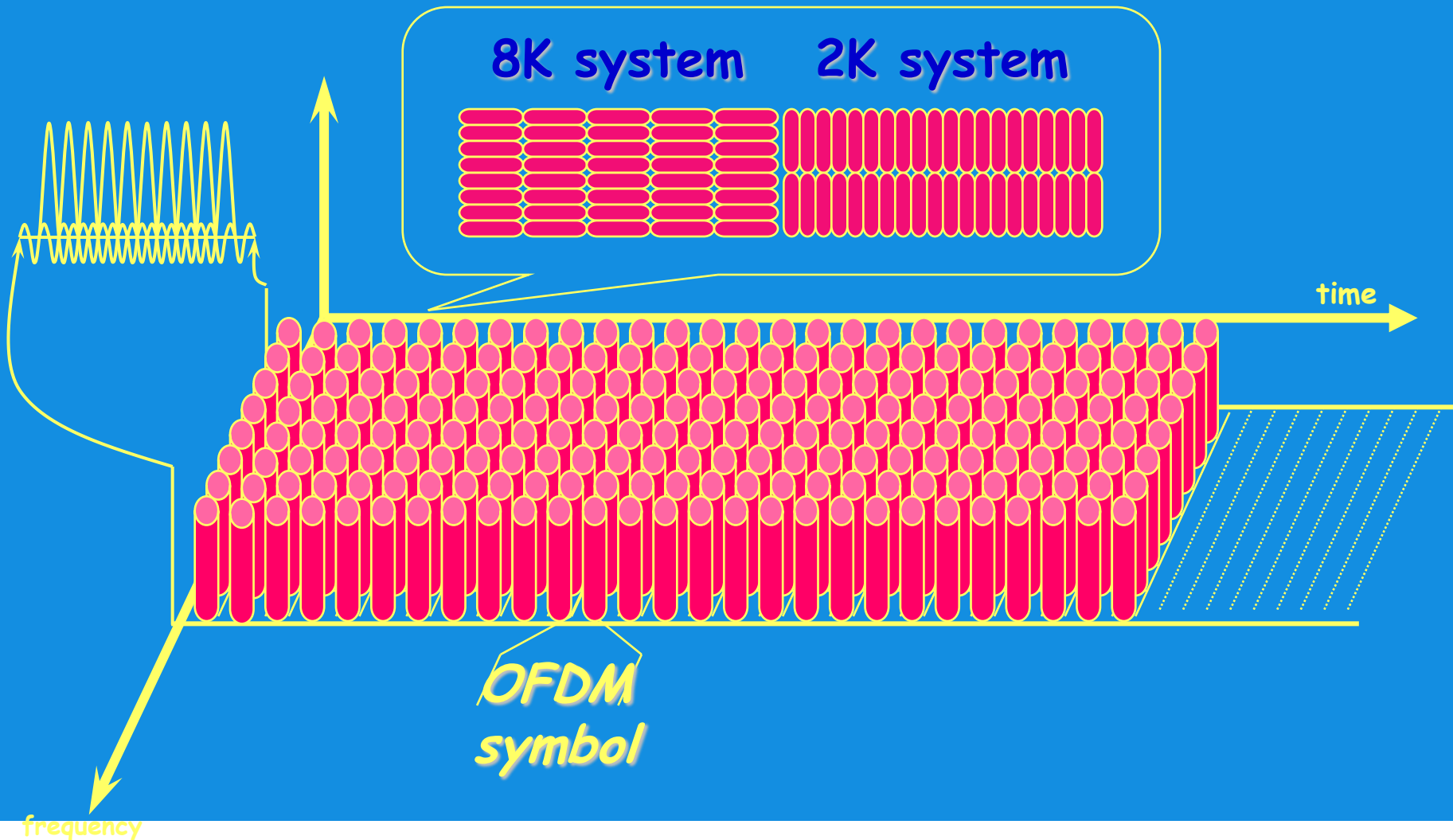

Sub-carriers are orthogonal ($df=1/dt$) to avoid “inter-carriers” interference

COFDM : HOW ?

- **3 - Insert Guard Interval to avoid “inter-symbol” interference**

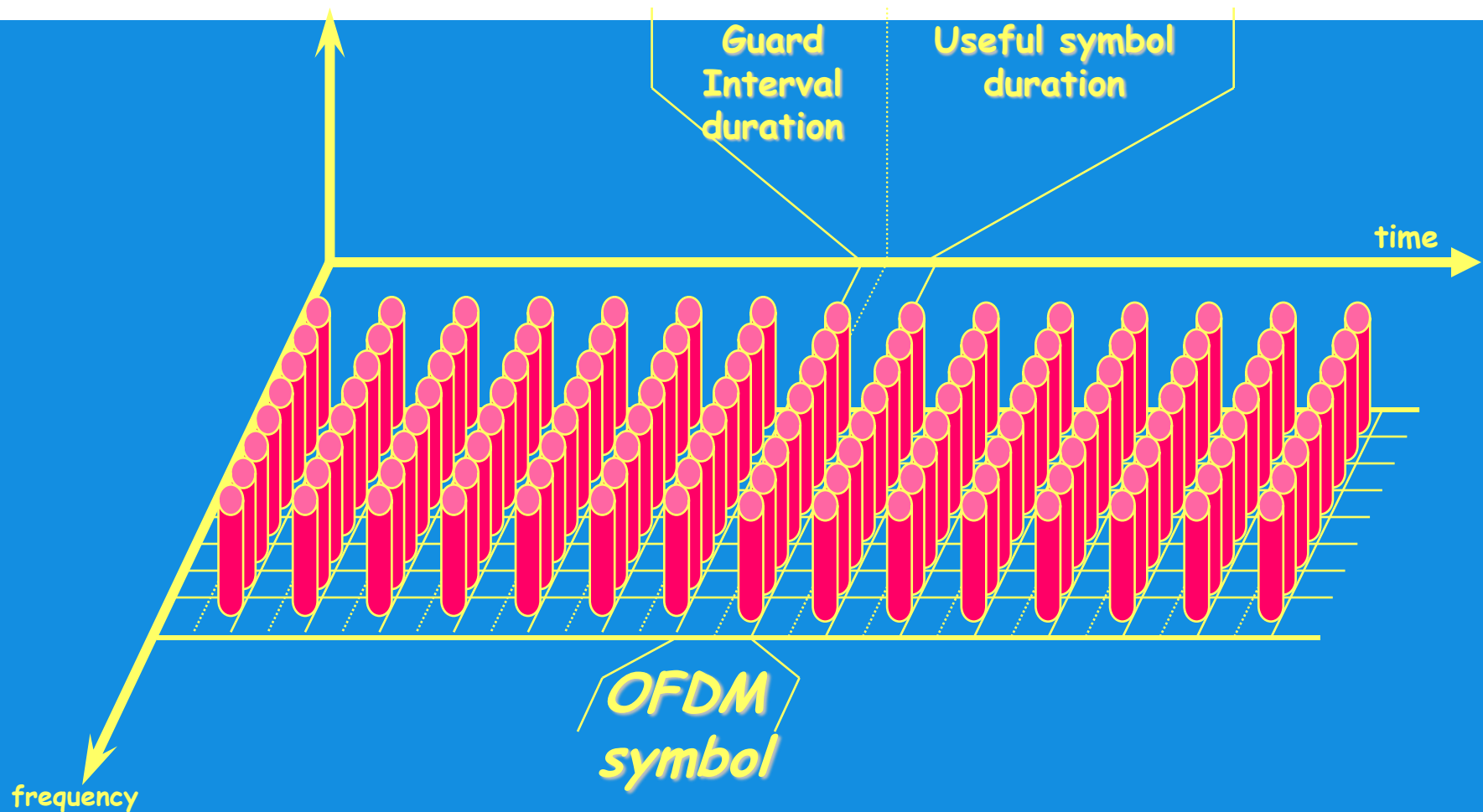

NOTE: Guard interval introduces the first loss in transport capacity

COFDM : HOW ?

- 4 - Insert “Synchronization Pilots” to help Receivers to lock onto the useful signal

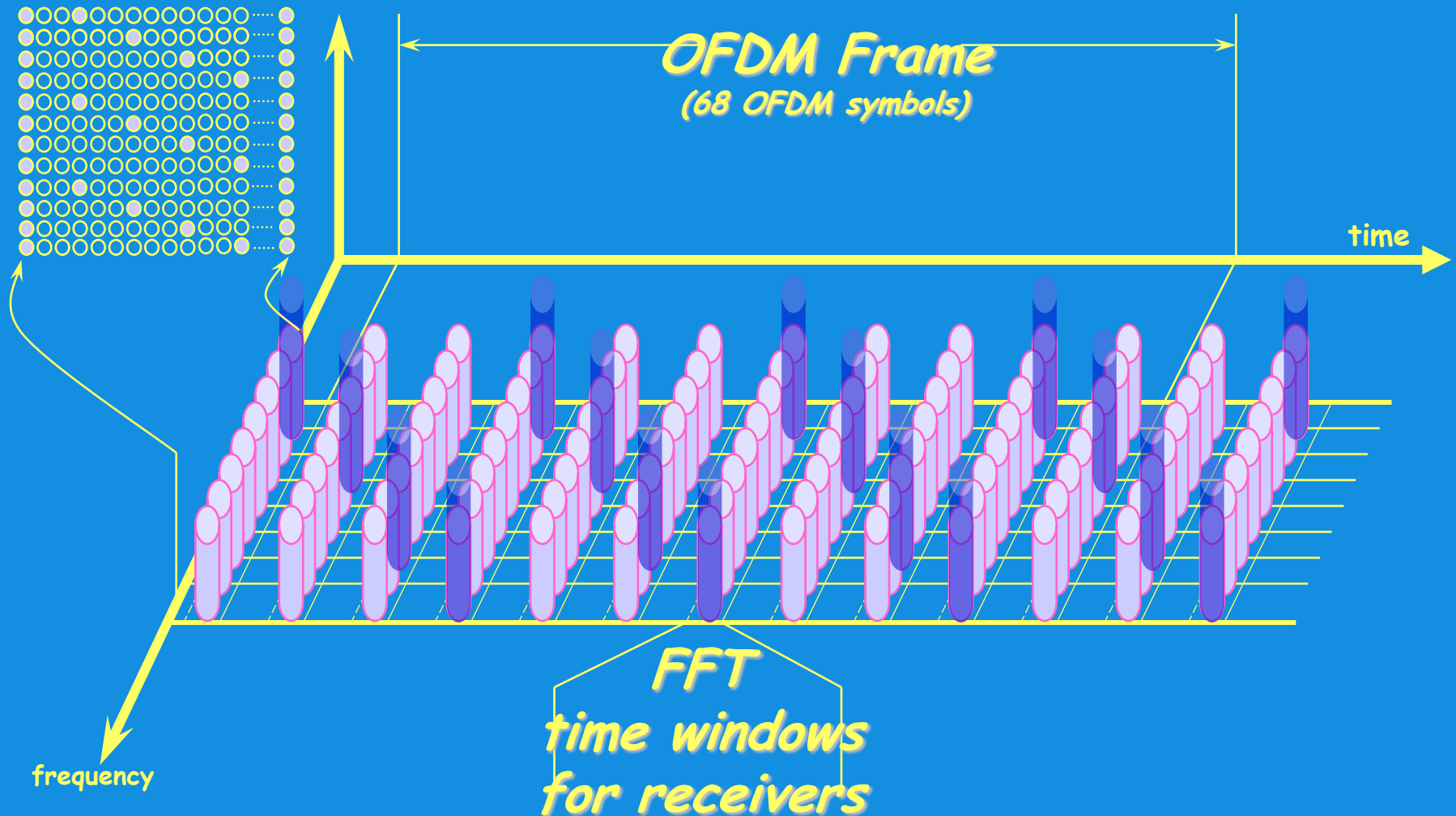

Note: Synchronization markers introduce a second loss in transport capacity

COFDM : HOW ?

- **5 - Prepare data to be carried on OFDM symbols**

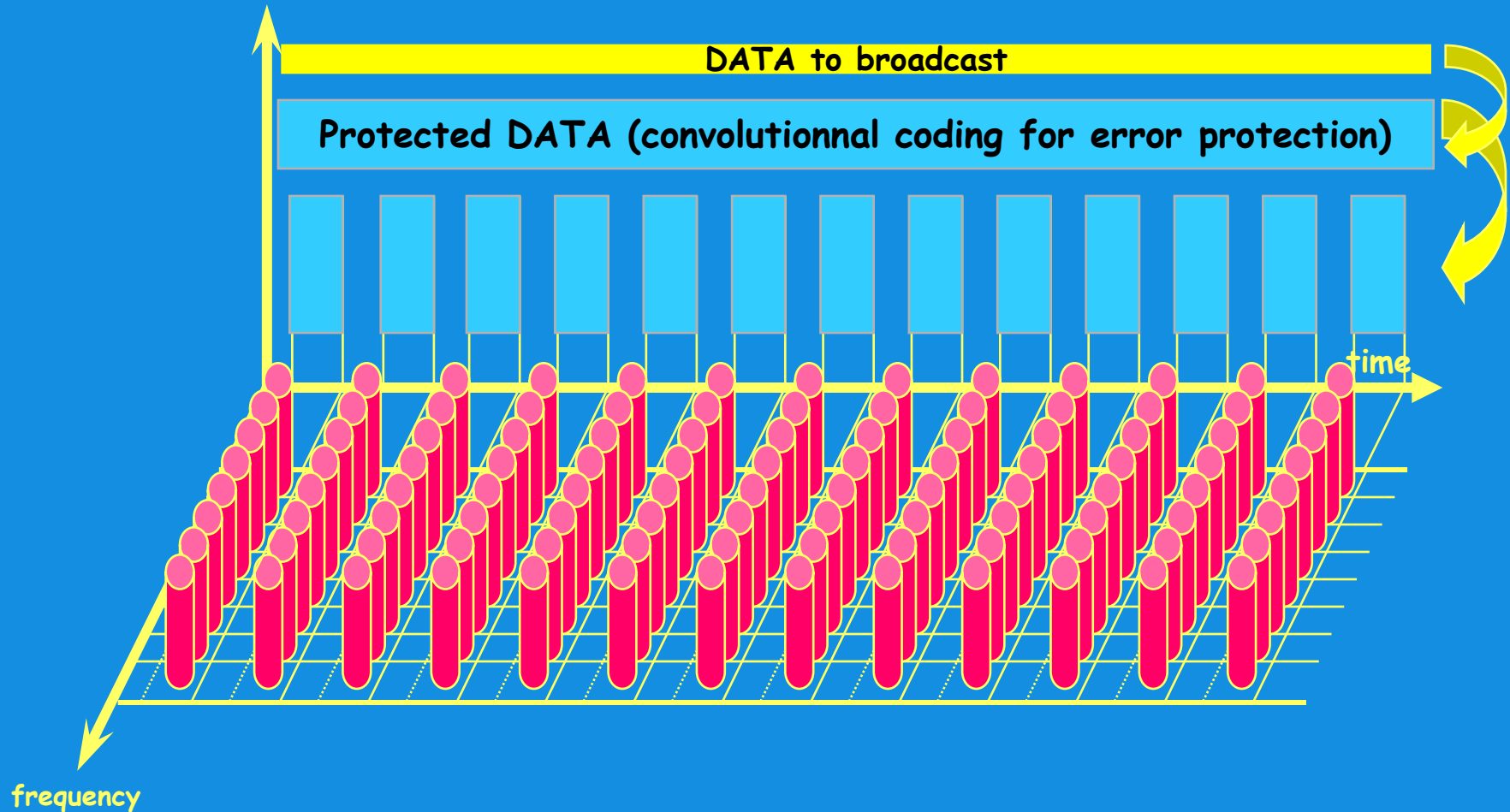

Note; Protection codes introduces a third loss in transport capacity

COFDM : HOW ?

- 6 - Map bits onto OFDM : spread contiguous data bits over distant sub-carriers

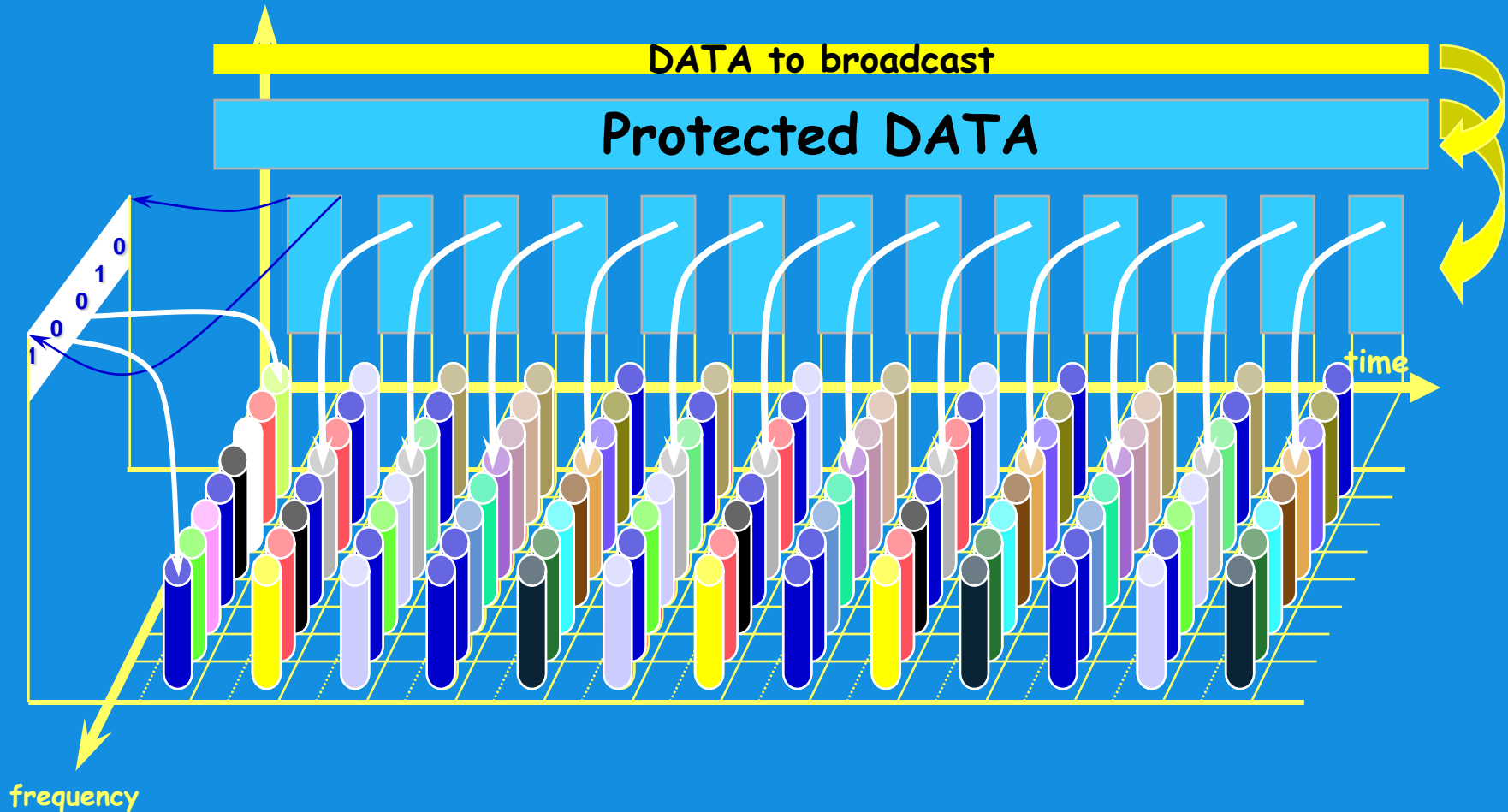

Create frequency diversity to improve robustness against selective fading

DVB-T

Parameter	8 k mode	2 k mode
Number of useful carriers / symbol	6 048	1 512
Number of carriers K	6 817	1 705
Value of carrier number K_{min}	0	0
Value of carrier number K_{max}	6 816	1 704
Duration T_U	896 μ s	224 μ s
Carrier spacing $1/T_U$	1 116 Hz	4 464 Hz
Spacing between carriers K_{min} and K_{max} $(K-1)/T_U$ (see note)	7,61 MHz	7,61 MHz
NOTE: 6,66 MHz in the case of 7 MHz wide channels.		

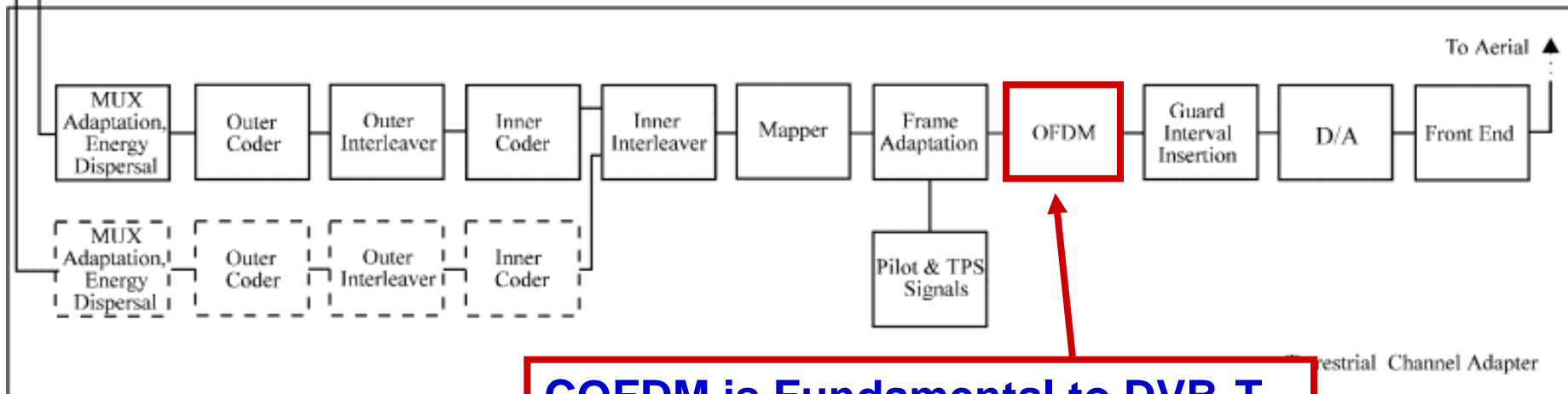
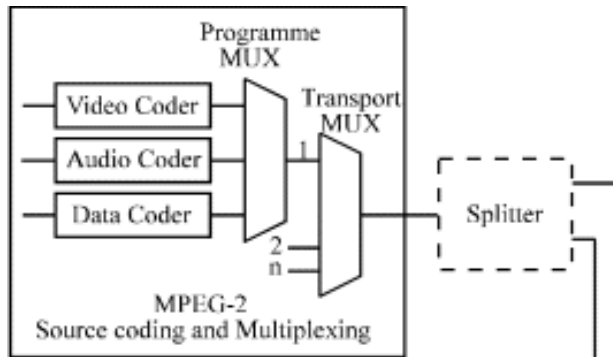

COFDM is Fundamental to DVB-T

DVB-T : Regular constellations

Data mapping is realised by applying one physical modulation to each sub-carrier

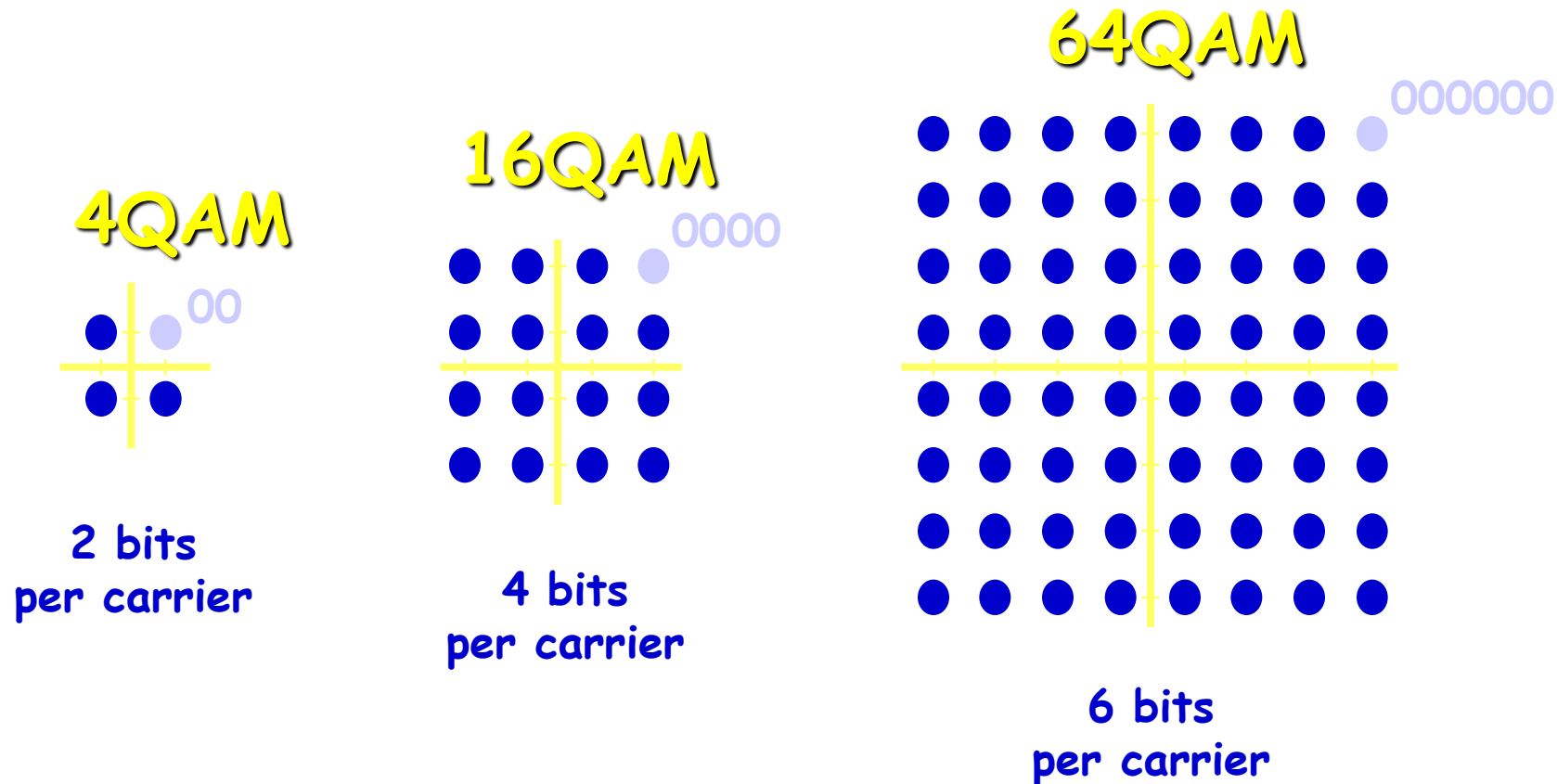

Each constellation gives to each sub-carrier a specific data transport capacity

64-QAM - Perfect & Failure

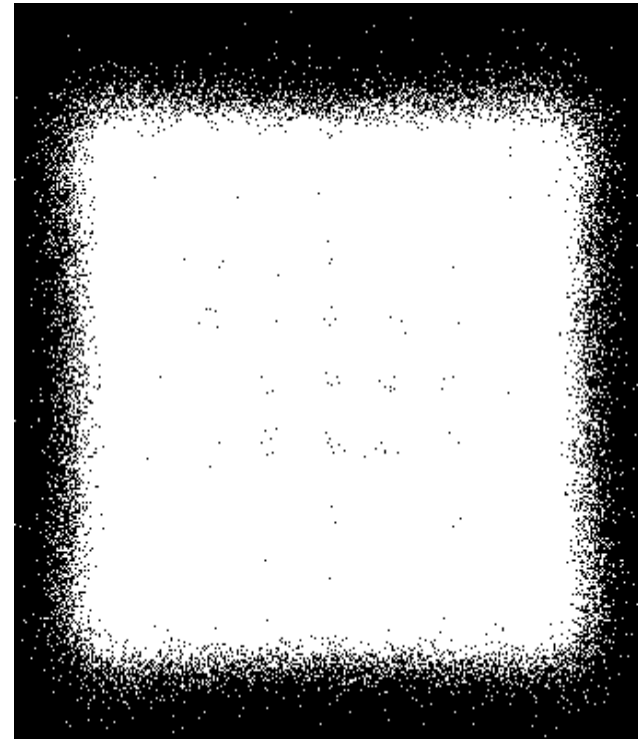
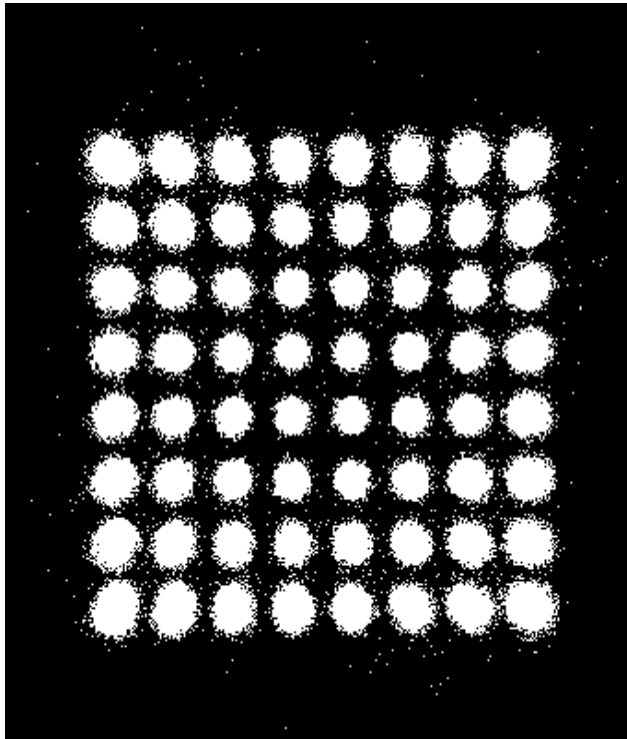

COFDM - Multipath

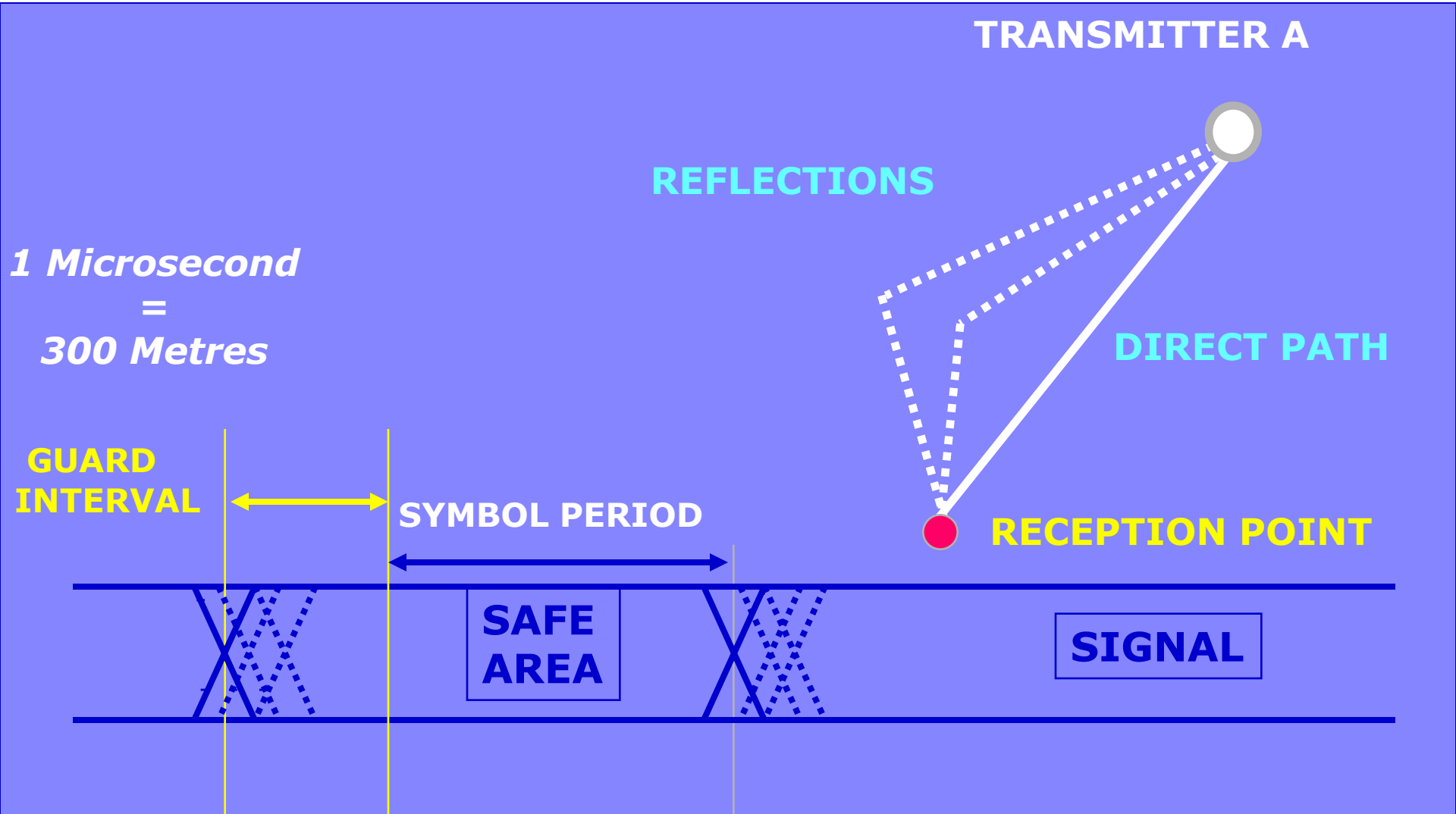

Single Frequency Networks

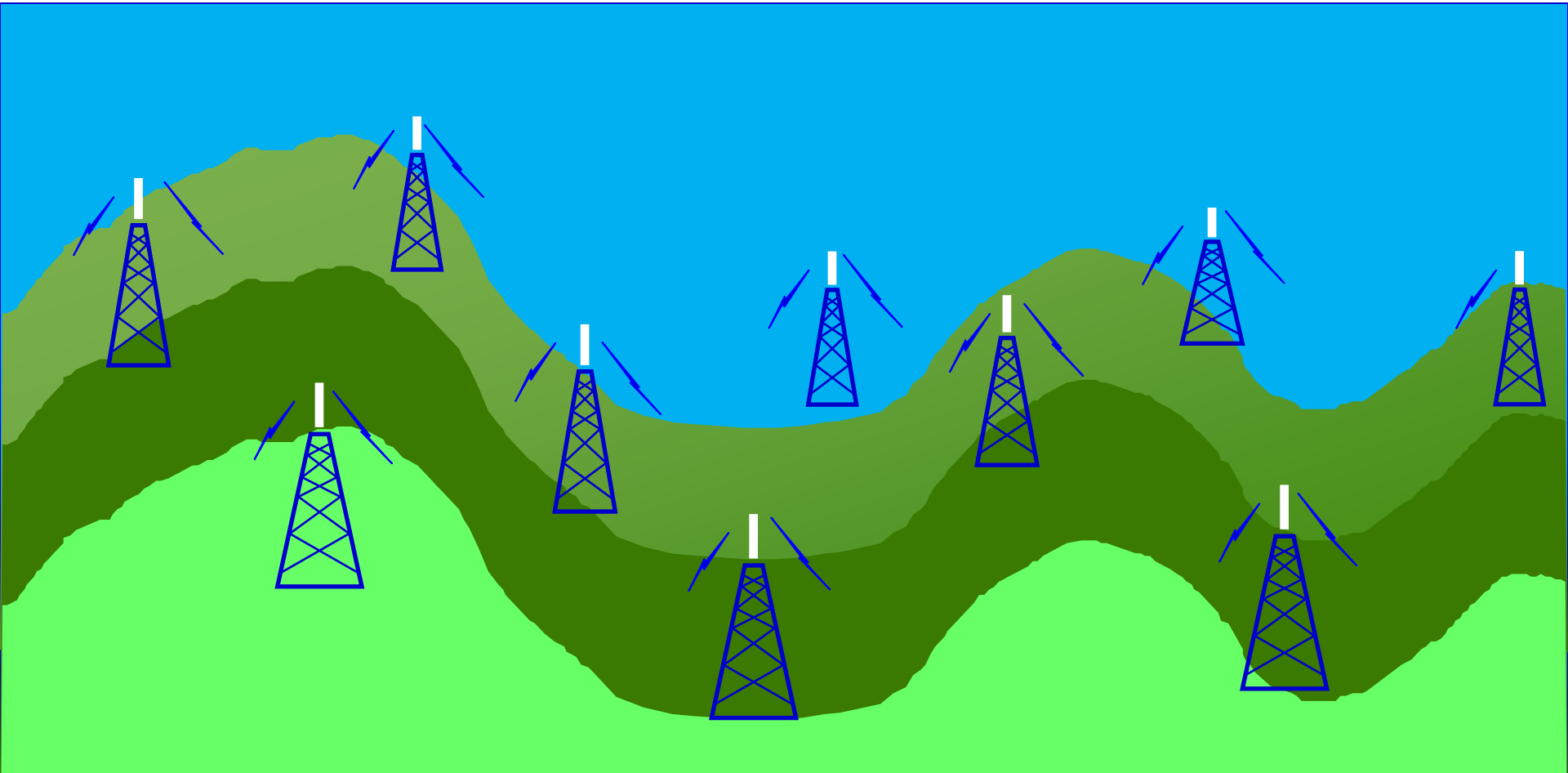

Field Strength Profile of SFN

COFDM - SFN

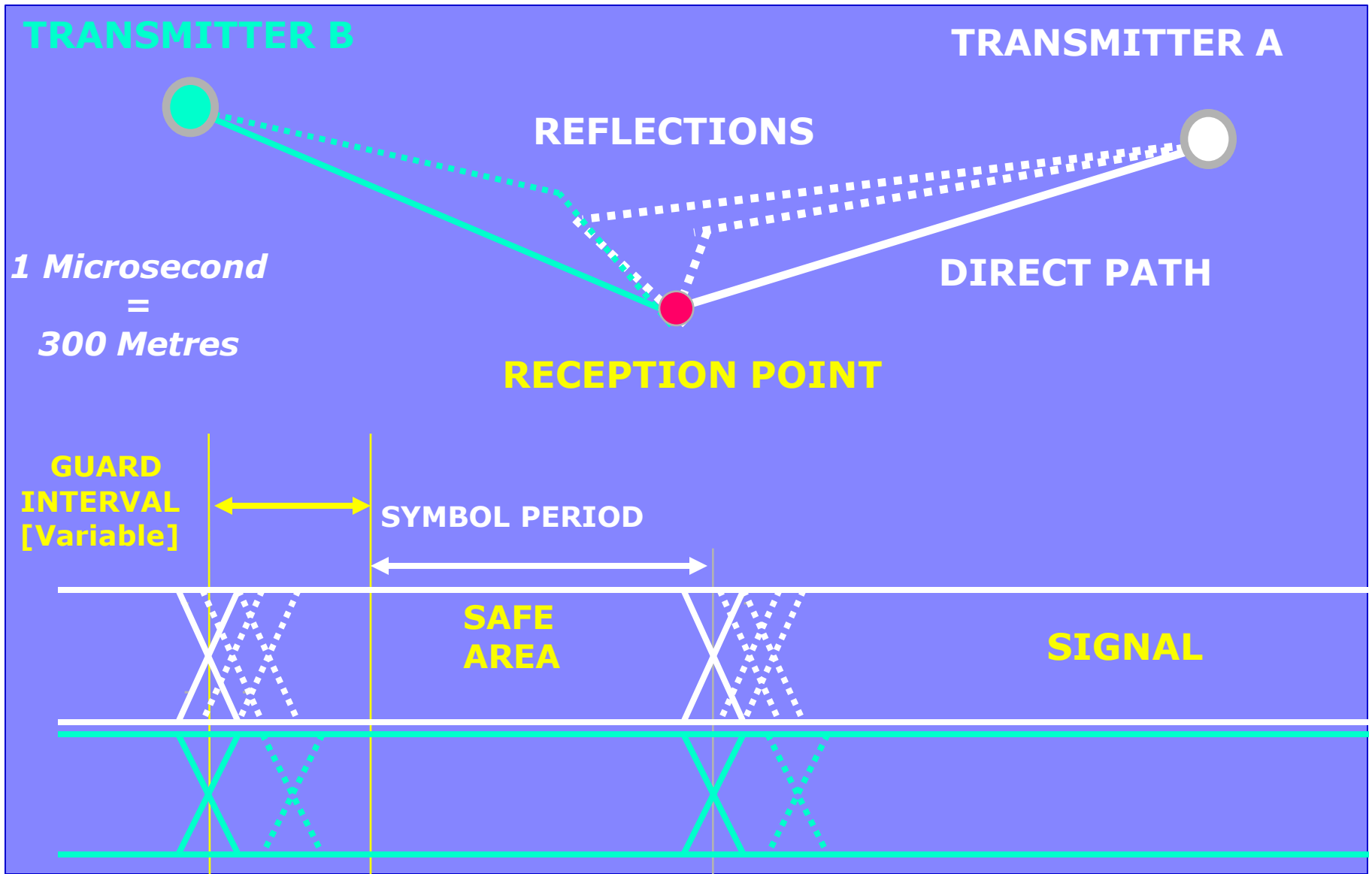

A little about DVB-T2 Technologies

DVB T2 *Birth Certificate*

TERRESTRIAL

Name : Second Generation of Digital Terrestrial TV
 Nick Name : DVB-T2
 Date of Birth : 26 June 2008 (59th DVB Steering Board)
 Standardisation : WAVEFORM ETSI EN 302 755 V1.1.1 (2009-06)
 GUIDE LINE ETSI TS 102 831 V1.1.1 (2009-10)
 2G DTTB SYSTEM ITU-R (R-REC-BT.1877 (2010-05))

Frequency bands : VHF & UHF ... Up to 3 GHz
 Signal Bandwidth : **1.75 MHz**, 5 / 6 / 7 / 8 MHz, **10 MHz**

Waveform : Multi-Carrier OFDM with cyclic prefix
 . Transmission MFN, SFN, SISO (1x1) & **MISO-Alamouti (2x1)** operation
 . FFT sizes **1K / 2K / 4K / 8K / 16K / 32K**
 . Guard Interval **1/128**, 1/32, 1/16, **19/256**, 1/8, **19/128**, 1/4

Framing :
 . Super Frame up to 64 seconds (256 T2 frames & FEF frames)
 . T2 frame basic Physical Layer Frame (up to 250 ms),
 . FEF frame Future Extension Frame (not specified)

SSS :
 . Synchronisation Preamble **P1** (1K OFDM with pre & post GI, DBPSK)
 . Signalling Preamble **P2** (OFDM symbol(s) immediately after P1)
 . Sounding 8 sets of Pilot Pattern (including Continuous & Scattered)

PAPR : **Peak to Average Power Reduction** (using ACE & TR)

. Pre-Processor **TS & GSE** converted in Physical Layer Pipes (**PLP**),
 . Input Processor PLP converted in Base Band Frames

. **BICM** Bit Interleaved Coded Modulation applied per PLP
 ↳ FEC LPDC + BCH (from DVB-S2)
 2 block sizes : 64800 & 16200 bits
 ↳ Code Rate 1/2, 3/5, 2/3, 3/4, 4/5, 5/6
 ↳ Constellation QPSK 16QAM 64QAM **256QAM**
 ↳ **Rotation** 29,0° 16,8° 8,6° atan(1/16)°
 . Interleaver Time Interleaver (up to 500 Kcells ~10 Mbits) per PLP,
 Frequency Interleaver per channel

ETSI EN 302 755 v1.1.1 (2009-09)
 European Standard (Telecommunications series)

Frame structure channel coding and modulation
 for a second generation digital terrestrial
 television broadcasting system (DVB-T2)



DVB
 Digital Video
 Broadcasting



DVB-T2: KEY FEATURES

- **LDPC (Low Density Parity Check) error correcting codes (> 30% improvement over R-S coding)**
- **256QAM, Increased FFT range & guard interval**
- **Extended Bandwidth**
- **Rotated Constellations**
- **OFDM Equalisation (overhead reduction 8%)**
- **Differentiated Protection (PLP)**
- **Interleaving (Bit, Time, & Frequency)**
- **Transmit diversity (Alamouti coding 30% SFN)**
- **Peak / Average power reduction (PAPR - 20%)**

DVB-T2: KEY FEATURES

- LDPC (Low Density Parity Check) error correcting codes (30% improvement over R-S coding)
- 256QAM, Increased FFT range & guard interval
- Extended Bandwidth
- Rotated Constellations
- OFDM Equalisation (overhead reduction 8%)
- Differentiated Protection (PLP)
- Interleaving (Bit, Time, & Frequency)
- Transmit diversity (Alamouti coding 30% SFN)
- Peak / Average power reduction (PAPR - 20%)

DVB-T2 : Regular constellations

Data mapping is realised by applying one physical modulation to each sub-carrier

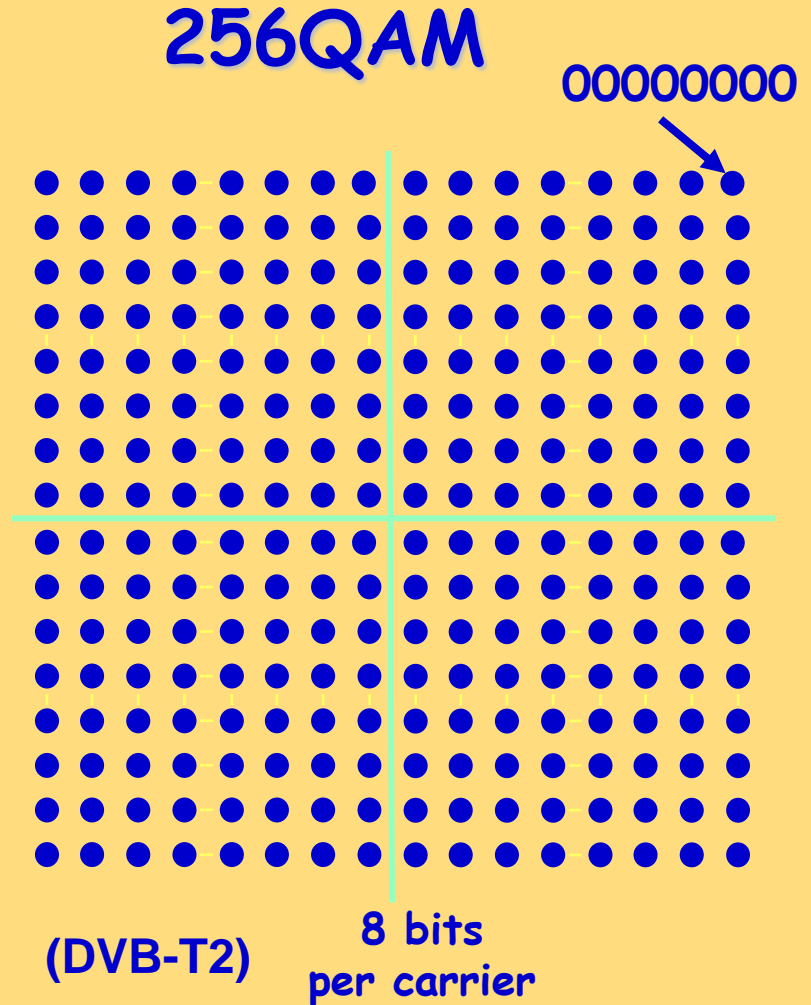
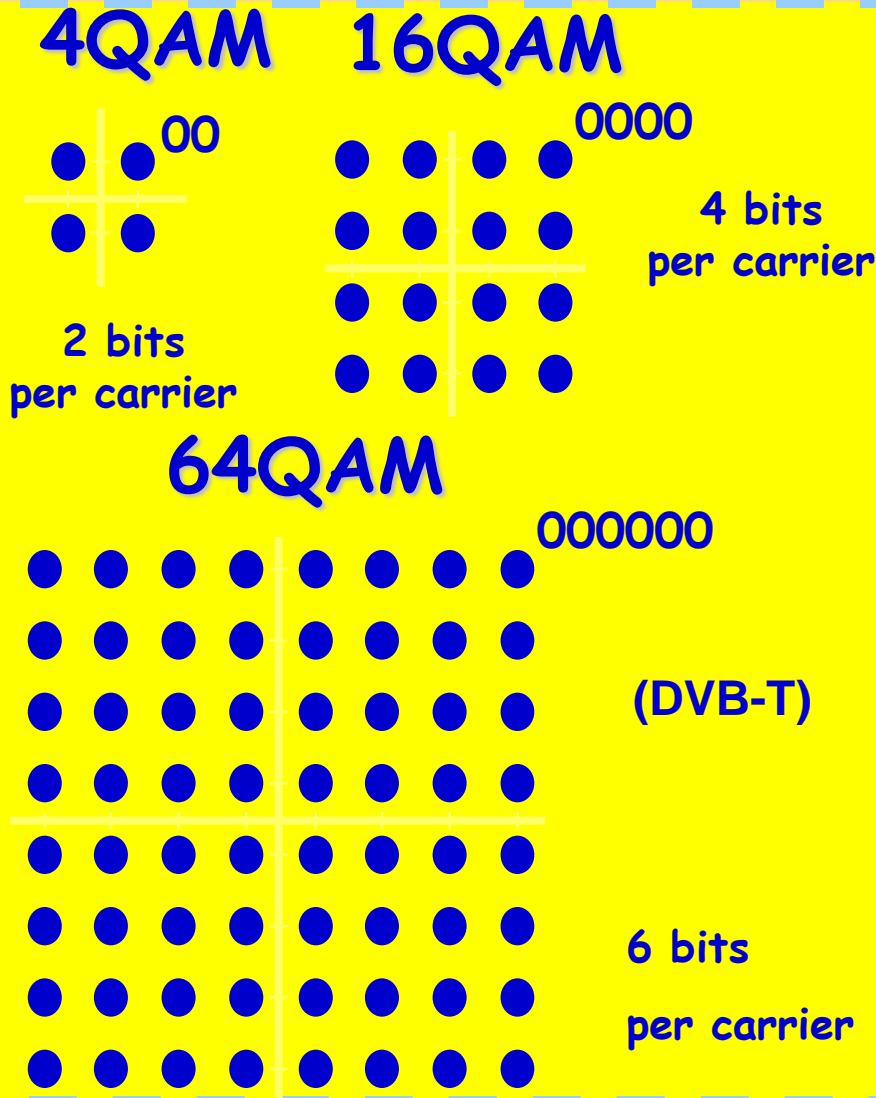

Each constellation gives to each sub-carrier a specific data transport capacity

Key Features: Modulation (1)

- T2 uses conventional **Guard-Interval OFDM (GI-OFDM)**
 - as in DVB-T, GI "absorbs" intersymbol interference due to echoes

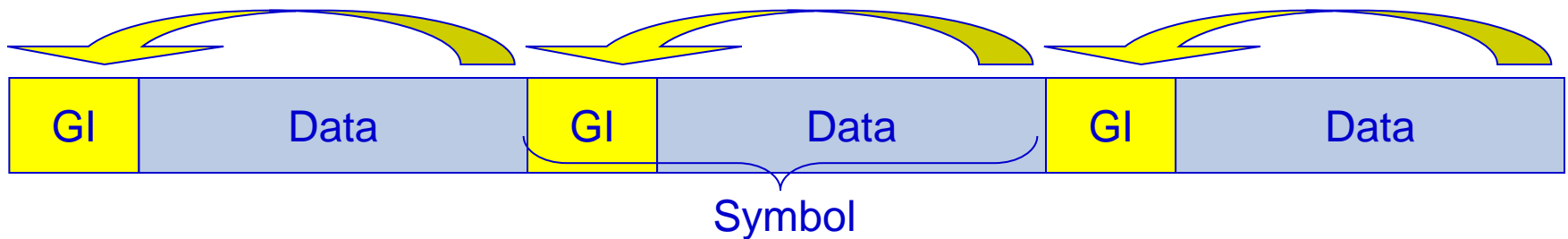

- Each symbol carries data on a large number of separate carriers
 - **1K, 2K, 4K, 8K, 16K, 32K** options are available in T2
 - 16K and 32K: to give improved SFN performance
 - **Increasing the number of carriers increases the symbol period: (1 ms for 8K;.....; 4 ms for 32K)**

Key Features: Modulation (2)

- Increasing the symbol period
 - Can reduce guard interval overhead for given size of SF

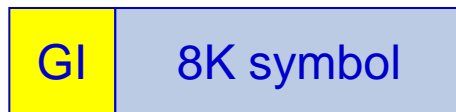

25% overhead TG=224 μ s (SFN: distance around 70 Km)



~6% overhead

- T2 extends guard interval range to allow reduced overhead and additional flexibility
 - **GIs in T2: 1/128, 1/32, 1/16, 19/256, 1/8, 19/128, 1/4**

DVB-T2: KEY FEATURES

- LDPC (Low Density Parity Check) error correcting codes (30% improvement over R-S coding)
- 256QAM, Increased FFT range & guard interval
- Extended Bandwidth
- Rotated Constellations
- OFDM Equalisation (overhead reduction 8%)
- Differentiated Protection (PLP)
- Interleaving (Bit, Time, & Frequency)
- Transmit diversity (Alamouti coding 30% SFN)
- Peak / Average power reduction (PAPR - 20%)

Key Features: Extended bandwidth mode

- Out of band spectrum for 32K mode falls away more quickly than spectrum for 2K mode
 - Allows 2% extra bandwidth/capacity whilst remaining within normal spectrum mask

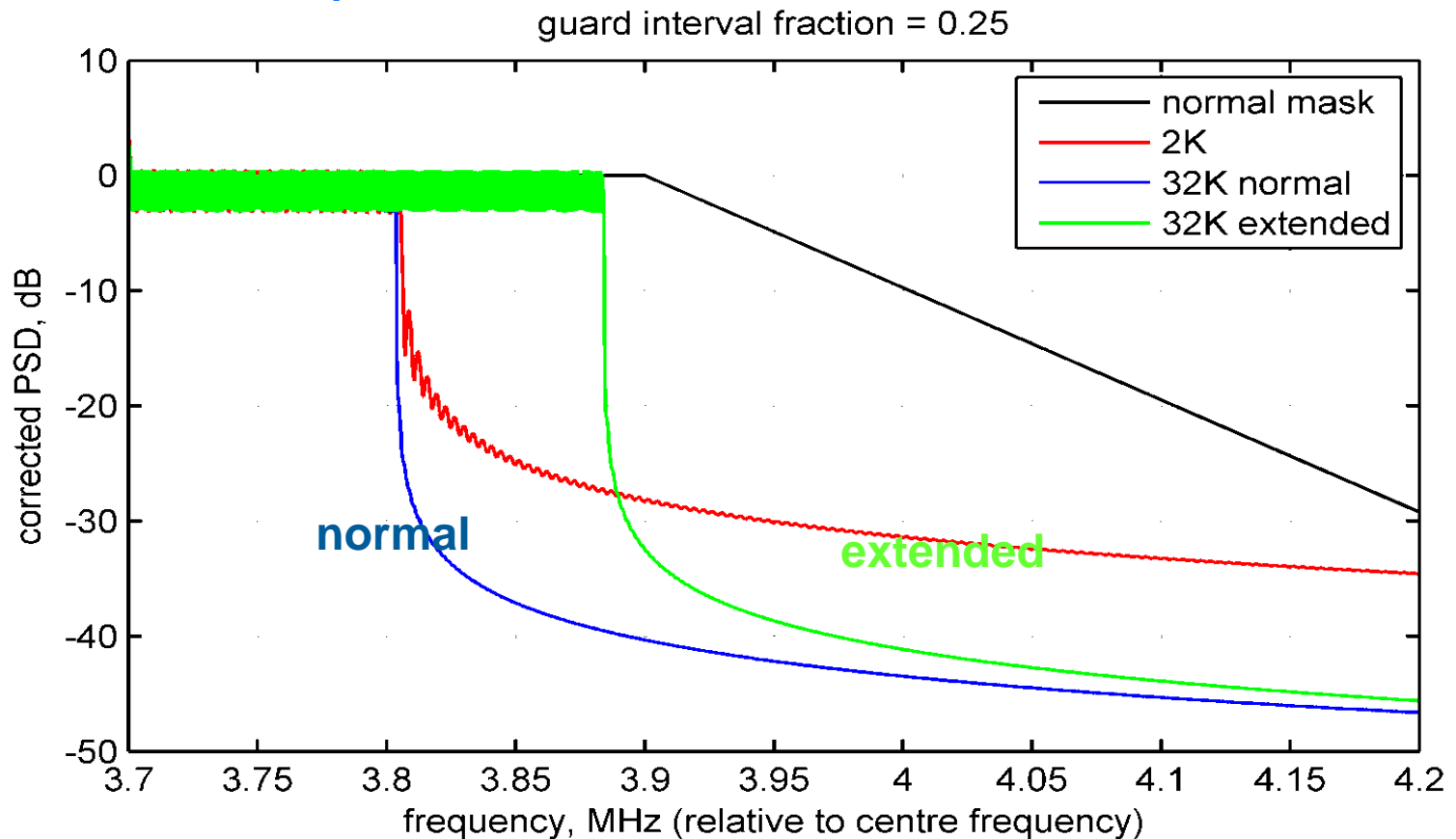

DVB-T2: KEY FEATURES

- LDPC (Low Density Parity Check) error correcting codes (30% improvement over R-S coding)
- 256QAM, Increased FFT range & guard interval
- Extended Bandwidth
- Rotated Constellations
- OFDM Equalisation (overhead reduction 8%)
- Differentiated Protection (PLP)
- Interleaving (Bit, Time, & Frequency)
- Transmit diversity (Alamouti coding 30% SFN)
- Peak / Average power reduction (PAPR - 20%)

BICM (BIT INTERLEAVED CODED MOD) MAPPER USES THE ROTATED CONSTELLATIONS

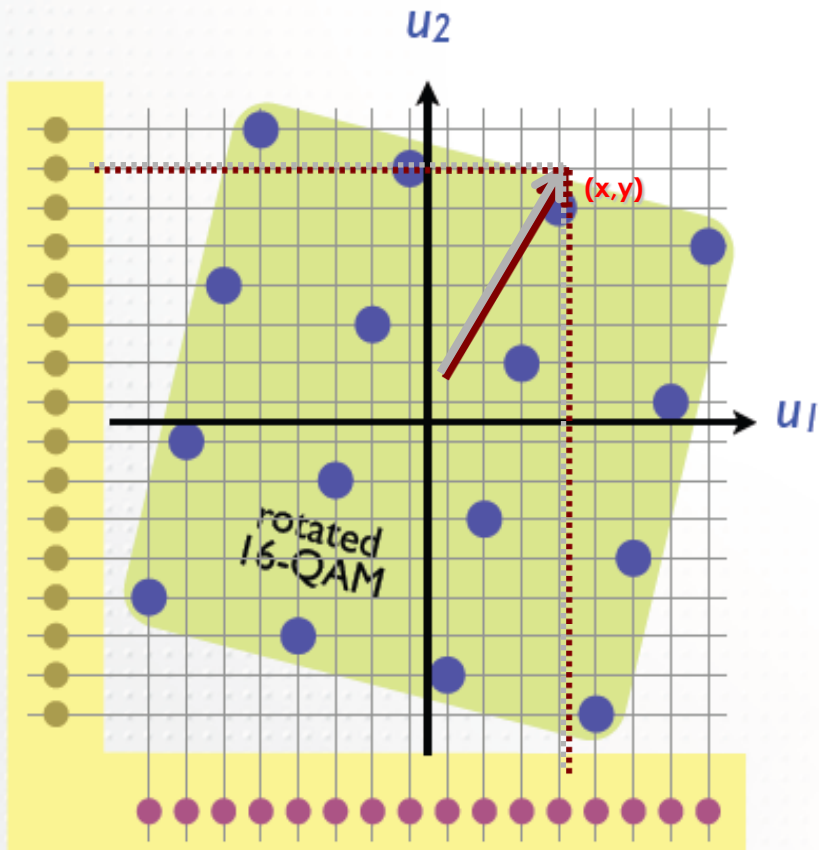

- 1) **TO MAP DATA BITS (X,Y) ONTO A NORMAL QAM**
 - ↪ (I,Q) can take each FOUR values
 - ↪ (I,Q) are required together to recover (x,y)
- 3) **IF THE QAM CONSTELLATION IS ROTATED**
 - ↪ (I,Q) become (u_1, u_2)
 - ↪ (u_1, u_2) can take each SIXTEEN values
- 4) **(U_1, U_2) CARRIES EACH ALL THE INFO OF (X, Y)**
 - ↪ Then only a single is required to recover (x,y) !!!!
- 5) **THEN ENSURE U_1 AND U_2 TRAVEL IN DIFFERENT SUB-CARRIER**
 - ↪ Probability to loss BOTH u_1 and u_2 decreases!
- 6) **RE-ASSEMBLES U_1 AND U_2 TOGETHER IN THE RECEIVER**
 - ↪ To recover (x,y) with either u_1 or u_2 only !

Rotated constellation A simple example

- One carrier is killed by multipath

The code reconstructs the destroyed info

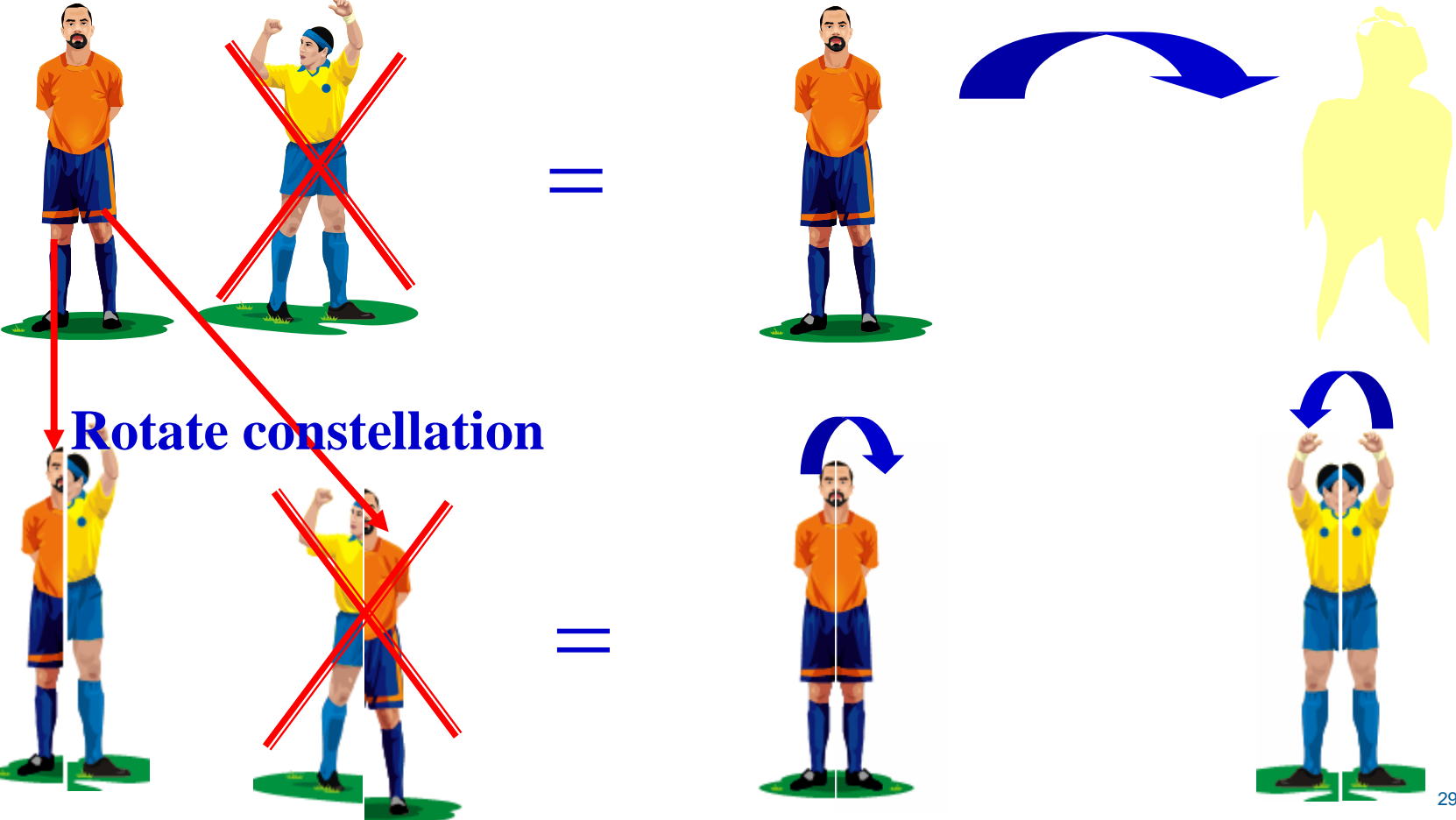

Rotated Constellations

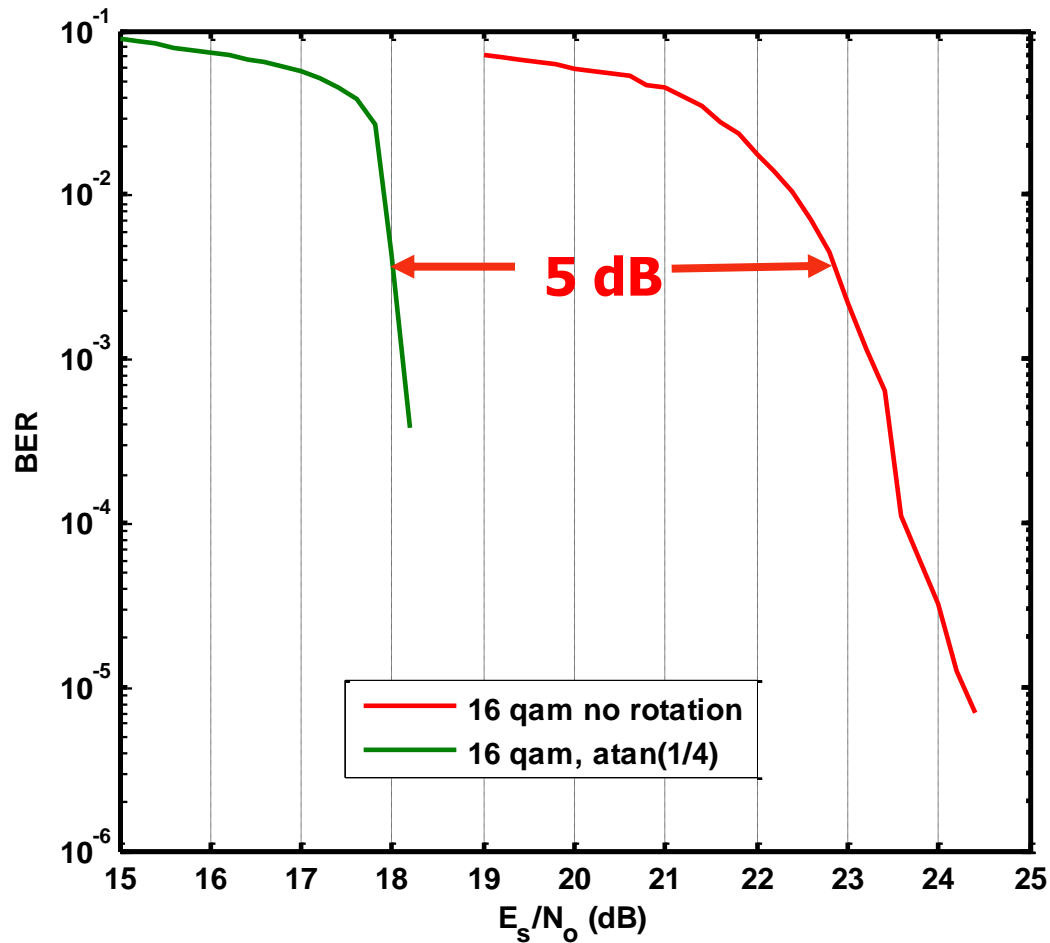

- Rotated constellations provide significantly improved robustness against loss of data cells
 - No degradation (nor gain) in Gaussian channel
 - Can achieve gains of 5 – 7 dB on difficult channels
 - e.g. 15% cell loss channel
 - Can translate into increased bit rate by choosing less robust FEC with lower overhead

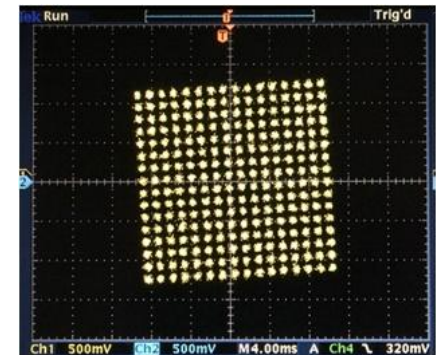

Comparison of performance for rotated/non-rotated constellations (code rate=4/5; channel = Rayleigh + 15% erasures of subcarriers)

DVB-T2: KEY FEATURES

- LDPC (Low Density Parity Check) error correcting codes (30% improvement over R-S coding)
- 256QAM, Increased FFT range & guard interval
- Extended Bandwidth
- Rotated Constellations
- OFDM Equalisation (overhead reduction 8%)
- Differentiated Protection (PLP)
- Interleaving (Bit, Time, & Frequency)
- Transmit diversity (Alamouti coding 30% SFN)
- Peak / Average power reduction (PAPR - 20%)

OFDM MODULATION : Choice of EIGHT PILOT PATTERNS TO TUNE OVERHEAD

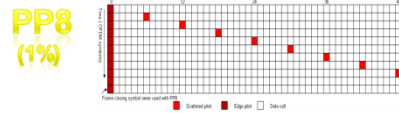
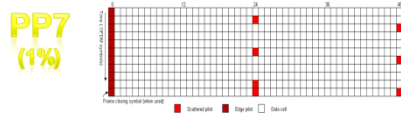
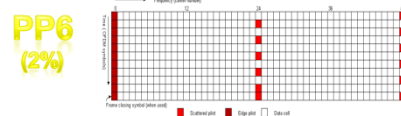
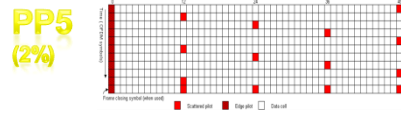
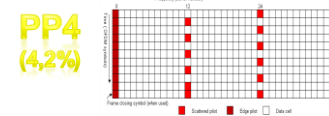
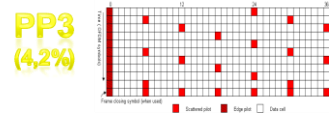
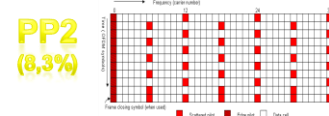
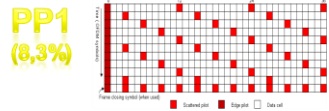

FFT size	Guard interval						
	1/128	1/32	1/16	19/256	1/8	19/128	1/4
32K	PP7	PP4 PP6	PP2 PP8 PP4	PP2 PP8 PP4	PP2 PP8	PP2 PP8	NA
16K	PP7	PP7 PP4 PP6	PP2 PP8 PP4 PP5	PP2 PP8 PP4 PP5	PP2 PP3 PP8	PP2 PP3 PP8	PP1 PP8
8K	PP7	PP7 PP4	PP8 PP4 PP5	PP8 PP4 PP5	PP2 PP3 PP8	PP2 PP3 PP8	PP1 PP8
4K, 2K	NA	PP7 PP4	PP4 PP5	NA	PP2 PP3	NA	PP1
1K	NA	NA	PP4 PP5	NA	PP2 PP3	NA	PP1

Less Pilots - Less Overhead

DVB-T2: KEY FEATURES

- LDPC (Low Density Parity Check) error correcting codes (30% improvement over R-S coding)
- 256QAM, Increased FFT range & guard interval
- Extended Bandwidth
- Rotated Constellations
- OFDM Equalisation (overhead reduction 8%)
- Differentiated Protection (PLP)
- Interleaving (Bit, Time, & Frequency)
- Transmit diversity (Alamouti coding 30% SFN)
- Peak / Average power reduction (PAPR - 20%)

DVB-T2: Multi layering with PLP's

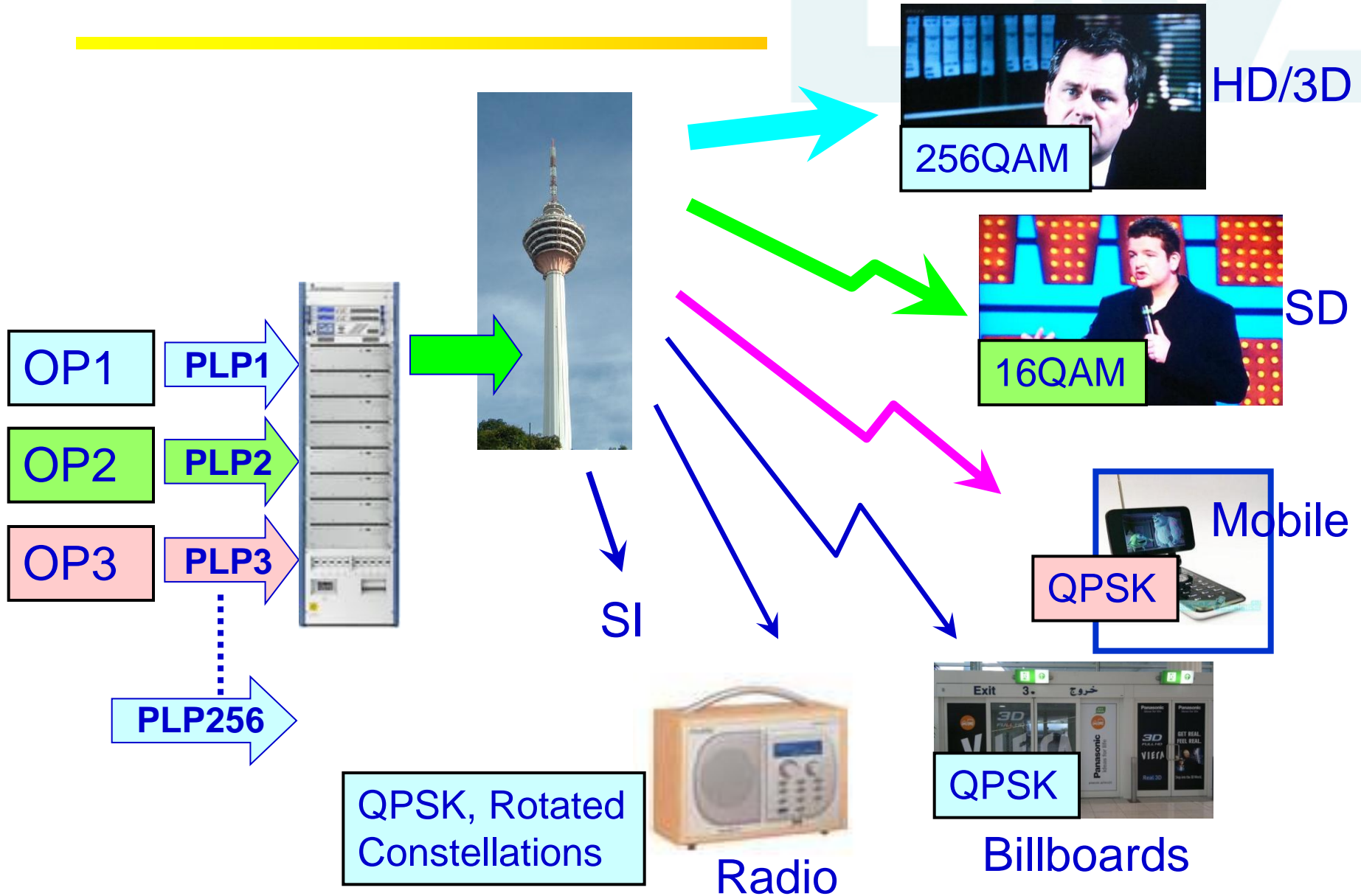

PLP provide Service Specific Robustness

- Each service can be given its own modulation mode (e.g. 256QAM, 16 QAM) and FEC coding rate (e.g. rate 3/5, rate 3/4)
- Different applications: roof-top reception/portables/ Handheld etc

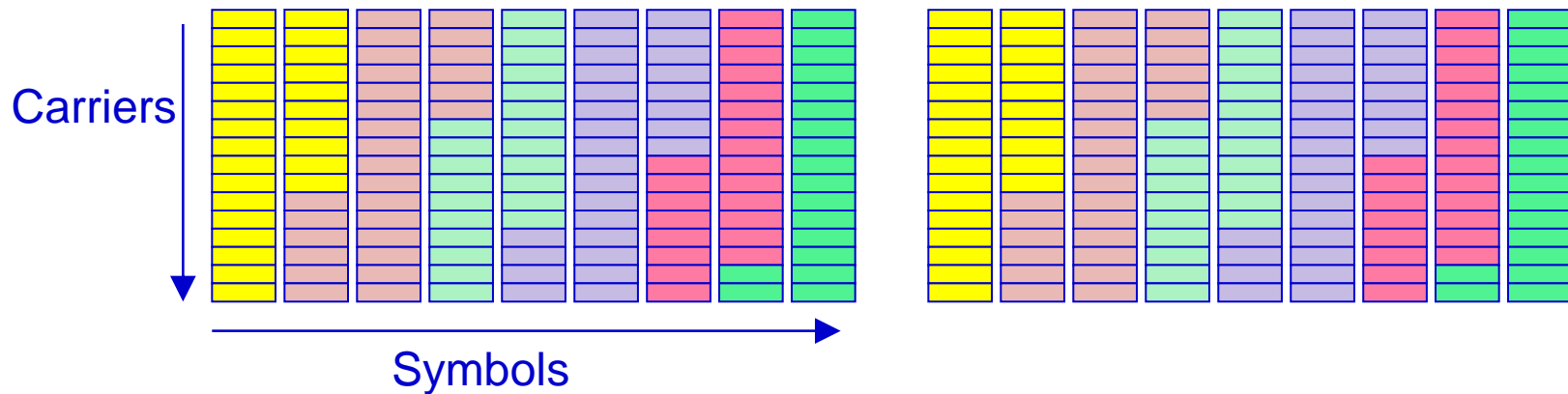

- Each service is given a slice of data cells within a frame
 - Each slice is part of a Physical Layer Pipe (PLP) for that service
 - Also enables power saving in the receiver

DVB-T2: KEY FEATURES

- LDPC (Low Density Parity Check) error correcting codes (30% improvement over R-S coding)
- 256QAM, Increased FFT range & guard interval
- Extended Bandwidth
- Rotated Constellations
- OFDM Equalisation (overhead reduction 8%)
- Differentiated Protection (PLP)
- Interleaving (Bit, Time, & Frequency)
- Transmit diversity (Alamouti coding 30% SFN)
- Peak / Average power reduction (PAPR - 20%)

Interleaving

- **T2 uses three main interleavers – applied per PLP**
 - **Bit Interleaving within an FEC block (BI)**
 - Based on a row/column block interleaver
 - **Time & Cell Interleaver (TI, CI)**
 - Disperses data cells from FEC blocks of a given service throughout slice (/subslices) for that service
 - **Frequency Interleaving (FI) (Similar to DVB-T)**
 - Causes randomisation of possibly-damaged adjacent data cells within an OFDM symbol
 - Provides robustness against a frequency-selective channel
 - T2 uses twin interleavers (**based on DVB-T interleaver**)

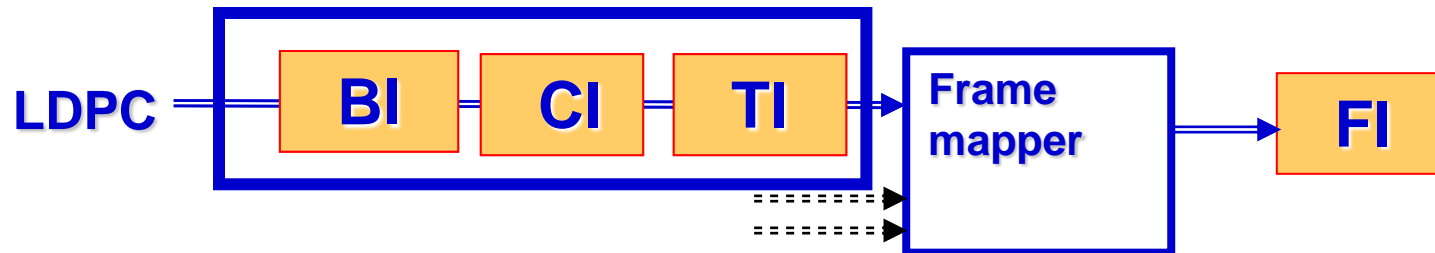

DVB-T2: KEY FEATURES

- LDPC (Low Density Parity Check) error correcting codes (30% improvement over R-S coding)
- 256QAM, Increased FFT range & guard interval
- Extended Bandwidth
- Rotated Constellations
- OFDM Equalisation (overhead reduction 8%)
- Differentiated Protection (PLP)
- Interleaving (Bit, Time, & Frequency)
- Transmit diversity (Alamouti coding 30% SFN)
- Peak / Average power reduction (PAPR - 20%)

Transmit Diversity using MISO

- T2 includes Alamouti coding mode for simple SFNs
 - While Tx1 transmits pair of data cells S_0, S_1 , Tx2 transmits $-S_1^*, S_0^*$
 - Also involves modification of pilot patterns to measure $h1$ and $h2$
 - Transmitters can be
 - Physically separated
 - Same locations `but using different polarisations

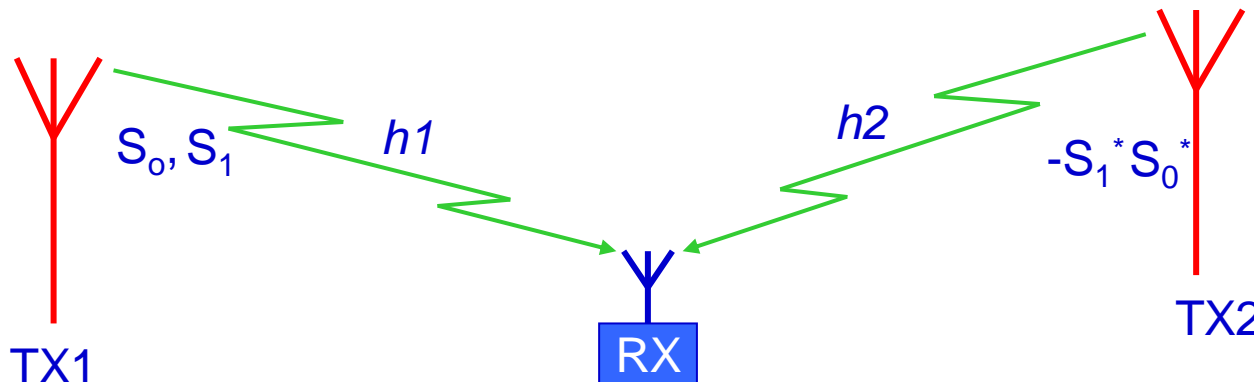

- Trial studies have shown 30% increase in coverage area for simple SFNs (2.5 db gain)

Transmit Diversity (2)

- Scattered pilot patterns are modified (for second transmitter) to enable measurement of channels h_1 and h_2 ; e.g. -

Transmitter 1

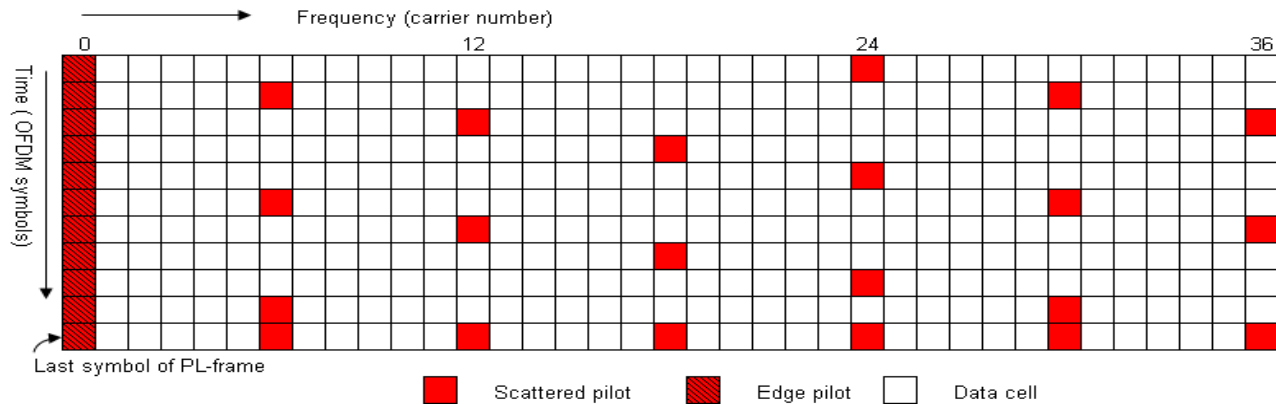

Transmitter 2

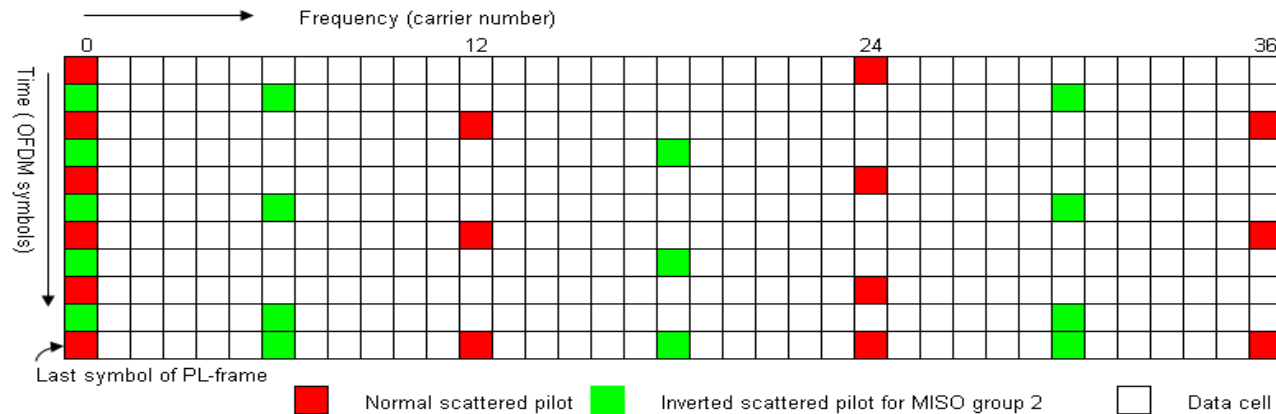

Simulation results for the SFN in Germany

static channel, 8 MHz, 8K, 16QAM, GI=1/4

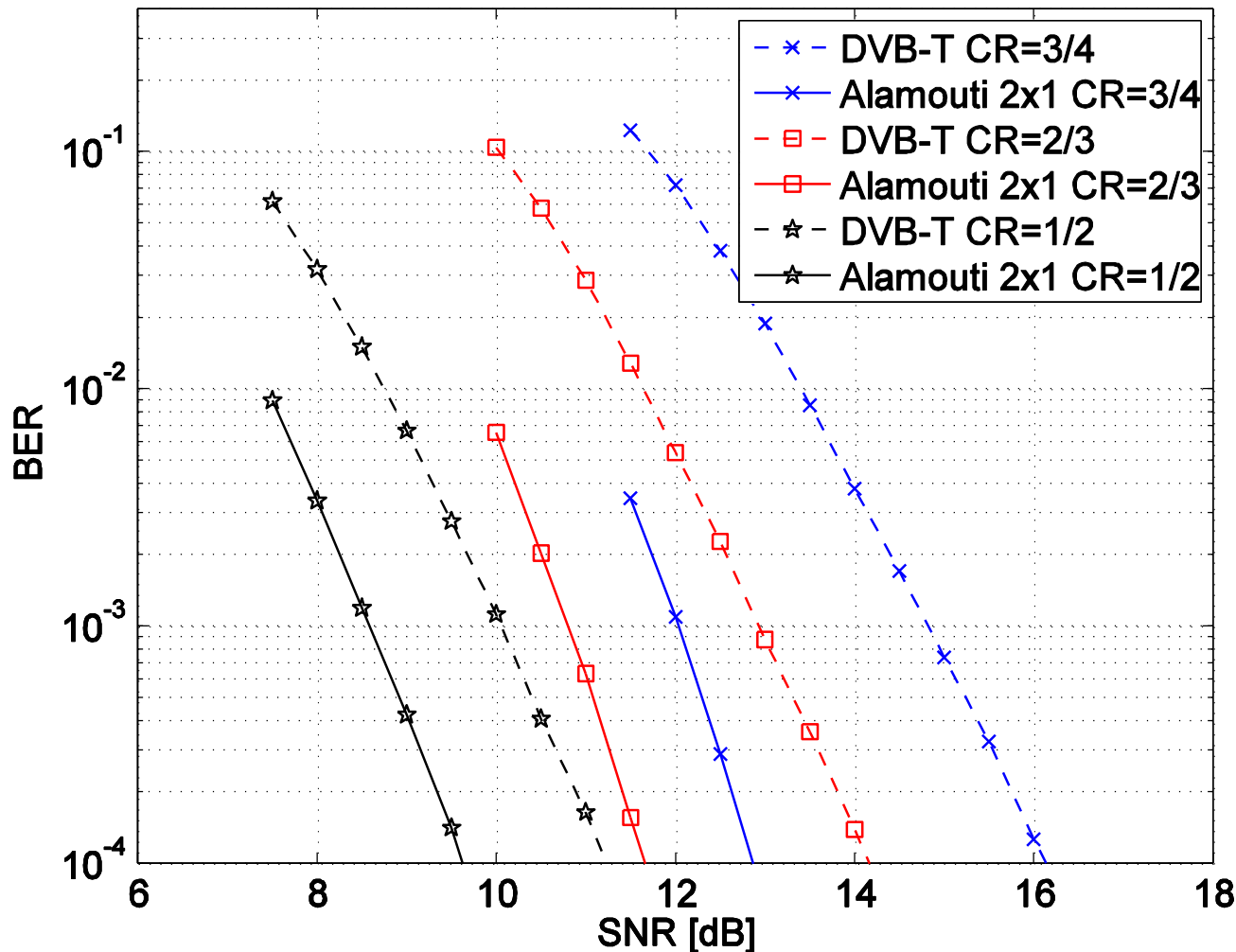

BER gain:
3dB for CR $\frac{3}{4}$
2.2dB for CR $\frac{2}{3}$
1.8dB for CR $\frac{1}{2}$

DVB-T2 Northern Germany.

Measurement results: MISO gain

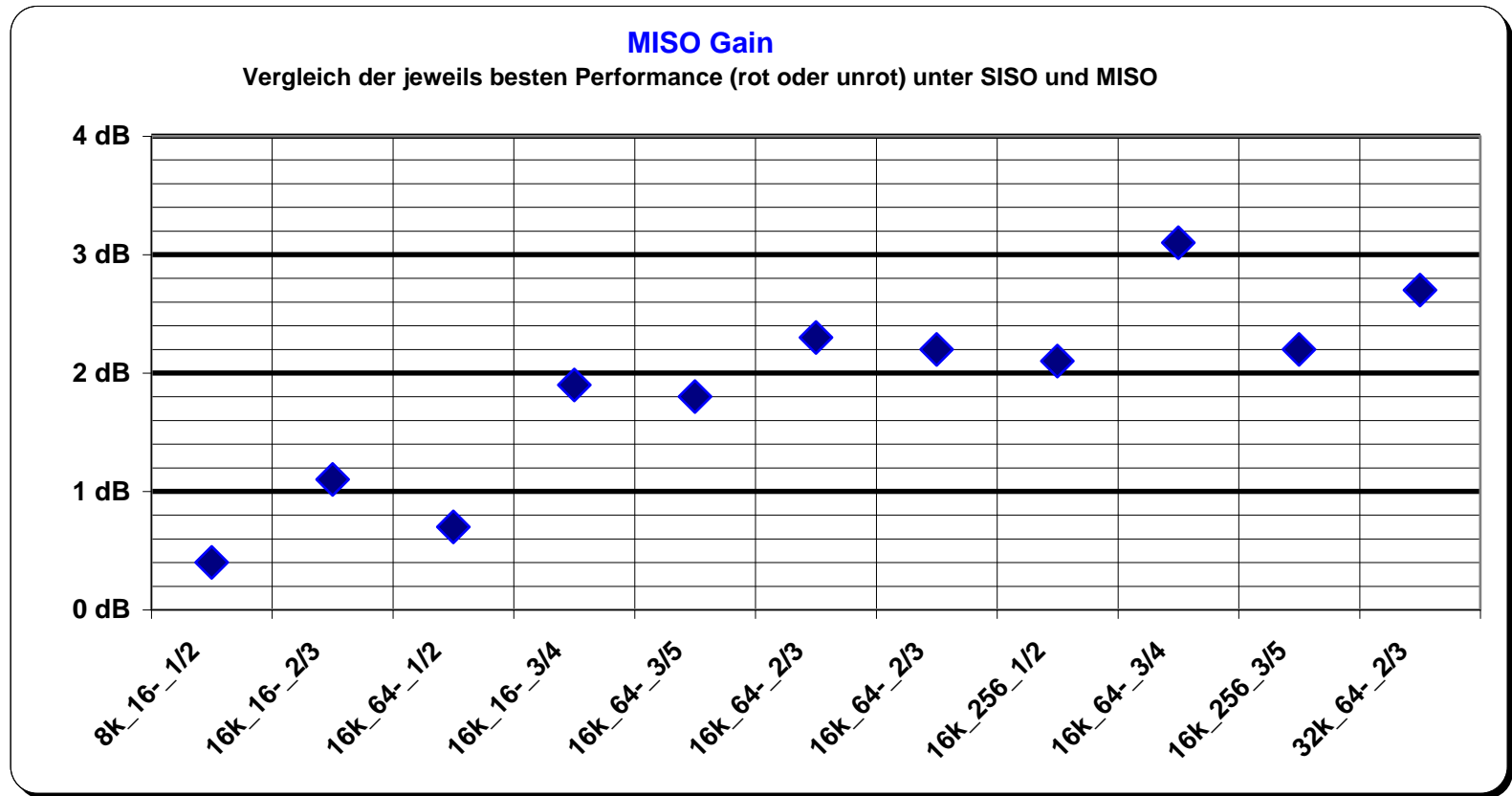

DVB-T2: KEY FEATURES

- LDPC (Low Density Parity Check) error correcting codes (30% improvement over R-S coding)
- 256QAM, Increased FFT range & guard interval
- Extended Bandwidth
- Rotated Constellations
- OFDM Equalisation (overhead reduction 8%)
- Differentiated Protection (PLP)
- Interleaving (Bit, Time, & Frequency)
- Transmit diversity (Alamouti coding 30% SFN)
- Peak / Average power reduction (PAPR - 20%)

Data rates provided and C/N values required in DVB-T2

Modulation Coderate	QPSK	16 QAM	64 QAM	256 QAM
1/2	7.5 Mbit/s 0.8 dB	15.0 Mbit/s 5.7 dB	22.5 Mbit/s 9.6 dB	30.1 Mbit/s 12.8 dB
3/5	9.0 Mbit/s 2.1 dB	18.1 Mbit/s 7.4 dB	27.1 Mbit/s 11.7 dB	36.2 Mbit/s 15.6 dB
2/3	10.0 Mbit/s 2.9dB	20.1 Mbit/s 8.6 dB	30.1 Mbit/s 13.2 dB	40.2 Mbit/s 17.5 dB
3/4	11.3 Mbit/s 3.9 dB	22.6 Mbit/s 9.8 dB	33.9 Mbit/s 14.9 dB	45.2 Mbit/s 17.5 dB
4/5	12.0 Mbit/s 4.5 dB	24.1 Mbit/s 10.6 dB	36.1 Mbit/s 15.9 dB	48.3 Mbit/s 21.1 dB
5/6	12.5 Mbit/s 5.0 dB	25.2 Mbit/s 11.2 dB	37.7 Mbit/s 16.6 dB	50.3 Mbit/s 21.8 dB

DVB-T: (most robust mode) **6 Mbit/s @ 3.5dB**

DVB-T: (maximum data rate) **31.7 Mbit/s @ 20.2dB**

DVB-T2 enables more services

SD TV **SD TV** **SD TV** **SD TV** **SD TV**
SD TV **SD TV** **SD TV** **SD TV** **SD TV**
SD TV **SD TV**
SD TV **SD TV**

Full HD
1080

Full
1080

Full HD
1080

Full
1080

1080

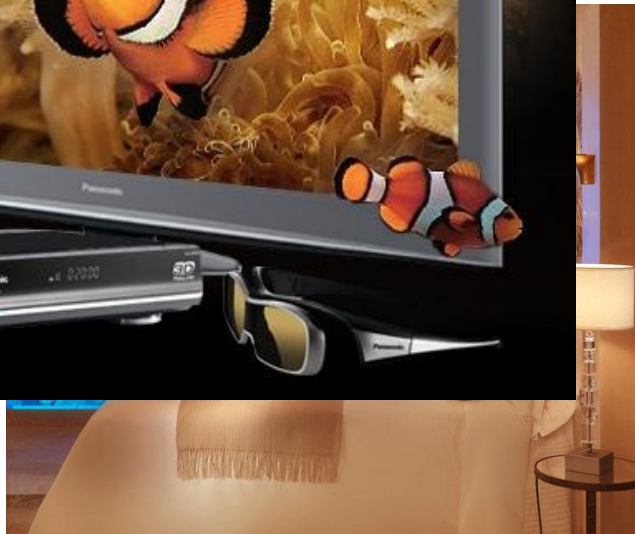

Modulation and Coding performance T2

Efficiency in Stationnary channels
Additional White Gaussian Noise - AWGN

(T2 : Red / T1 : Blue)

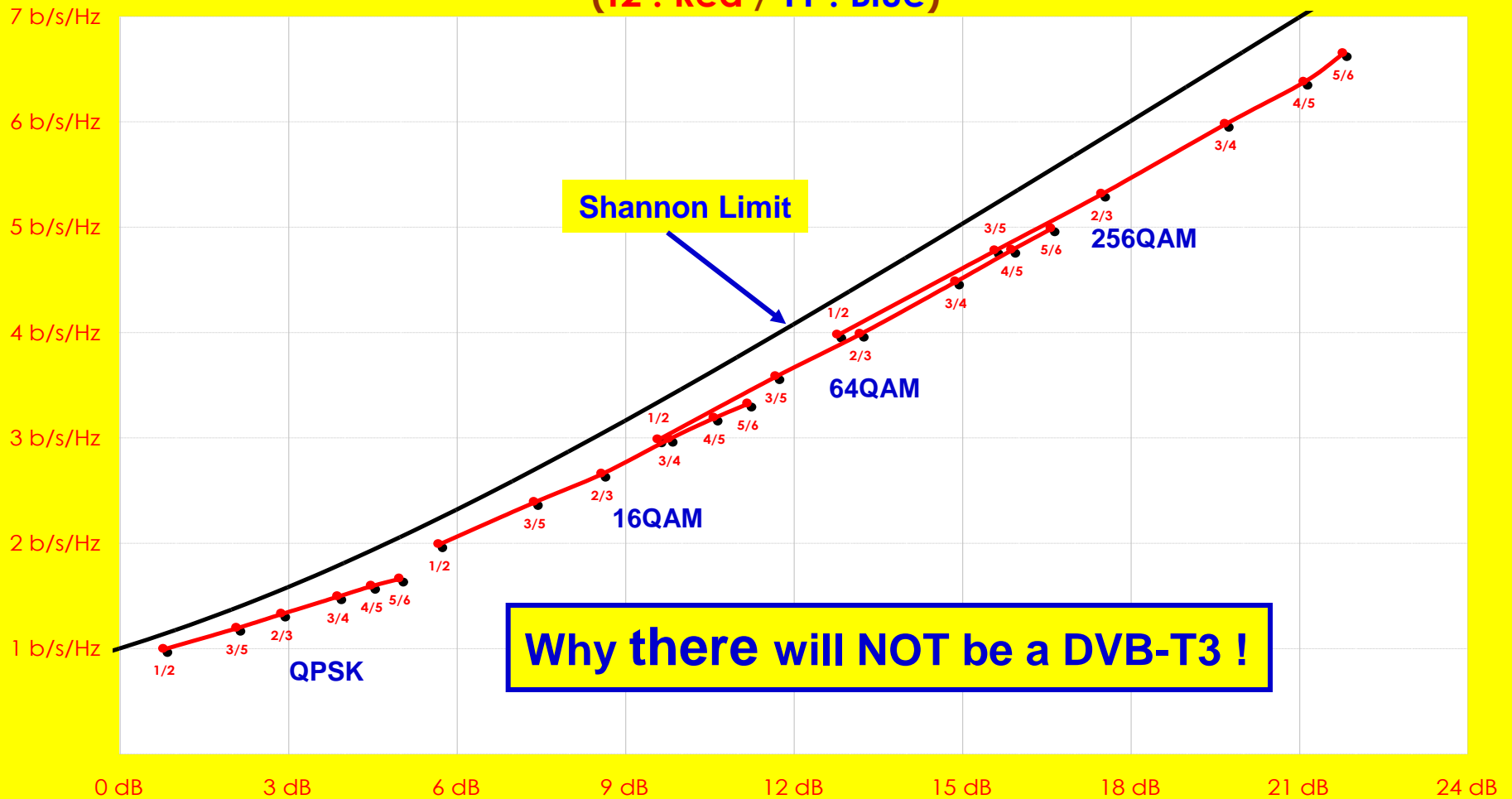

DVB-T2 Technical Comparison

	DVB-T		DVB-T2	
COFDM	Guard Interval OFDM		Guard Interval OFDM	
FEC	5	Reed Solomon 1/2; 2/3; 3/4; 5/6; 7/8	6	Low Density Parity Check 1/2; 3/5; 2/3; 3/4; 4/5; 5/6
Modes	3	QPSK; 16QAM; 64QAM	4	QPSK; 16QAM; 64QAM; 256QAM
Guard Interval	4	1/4; 1/8; 1/16; 1/32	8	1/4; 5/32; 1/8; 5/64; 1/16; 1/32; 1/64; 1/128
FFT size	2	2K; 8K	6	1K; 2K; 4K; 8K; 16K; 32K
Scattered Pilots	12%		1%	
Continual Pilots	2.6%		0.35%	

Comparison Capacity DVB-T / DVB-T2 (UK)

	DVB-T	T2
Modulation	64QAM	256QAM
FFT size	2K	32K
Guard Interval	1/32	1/128
FEC	2/3 CC + RS (8%)	2/3 LDPC + BCH (0.3%)
Scattered Pilots	8%	1%
Continual Pilots	2.6%	0.35%
P1/P2 overhead	0%	0.7%
Bandwidth	Standard	Extended
Capacity	24.1 Mbit/s	40.2 Mbit/s

Source: OFCOM

Capacity of DVB-T2 = DVB-T + 66%
4 - 6 HDTV channels in MPEG-4 (or 12-16 SDTV)

DVB-T2 Trial @ ABU Symposium



Ch46



idTV

STB

R & S ETL TV Analyser

Payload 40.2 Mb/s – 4 x HD services + MHEG services

DVB-T2 Relative Performance

DVB-T - Gaussian Transmission Performance (AWGN)

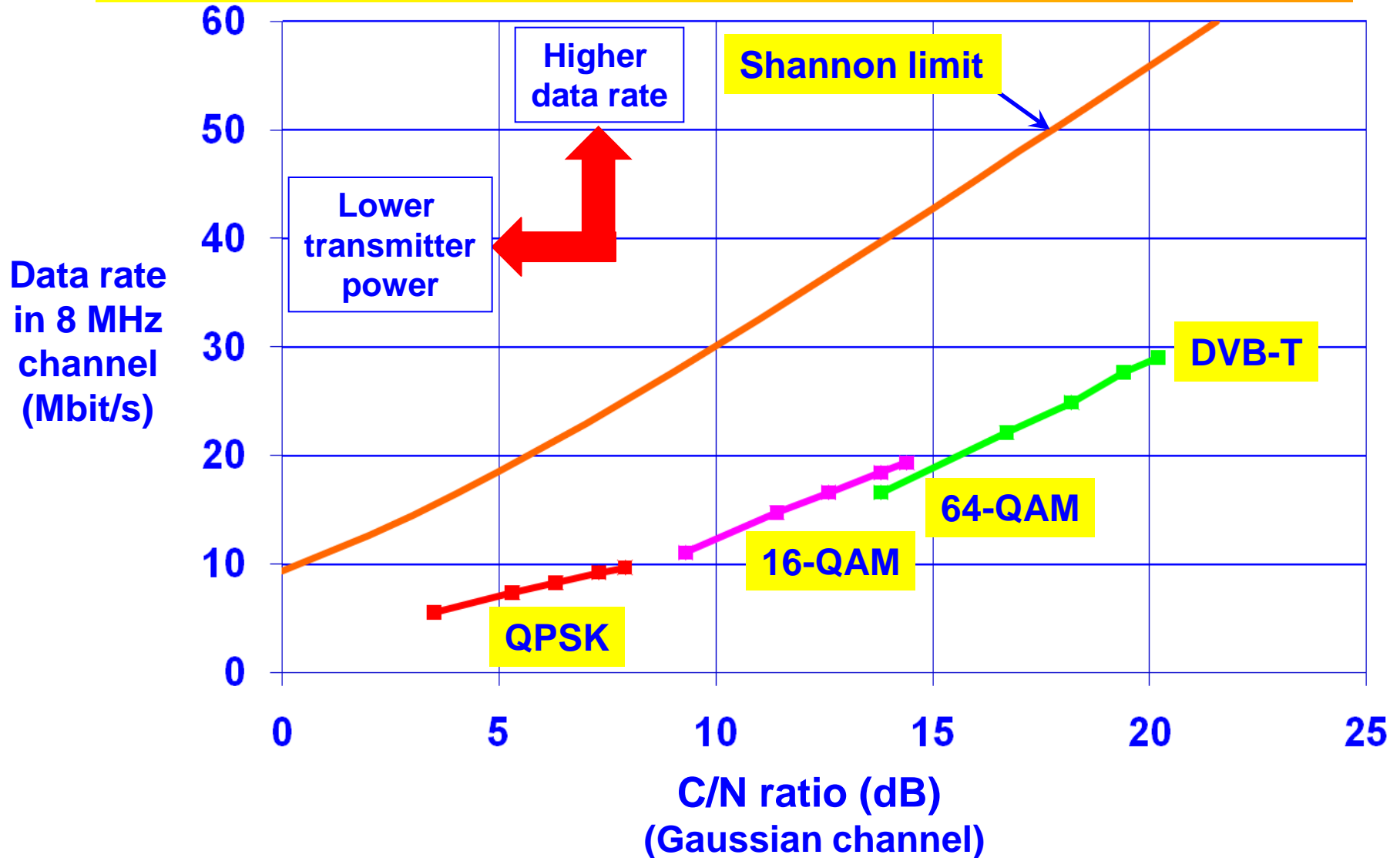

DVB-T & DVB-T2

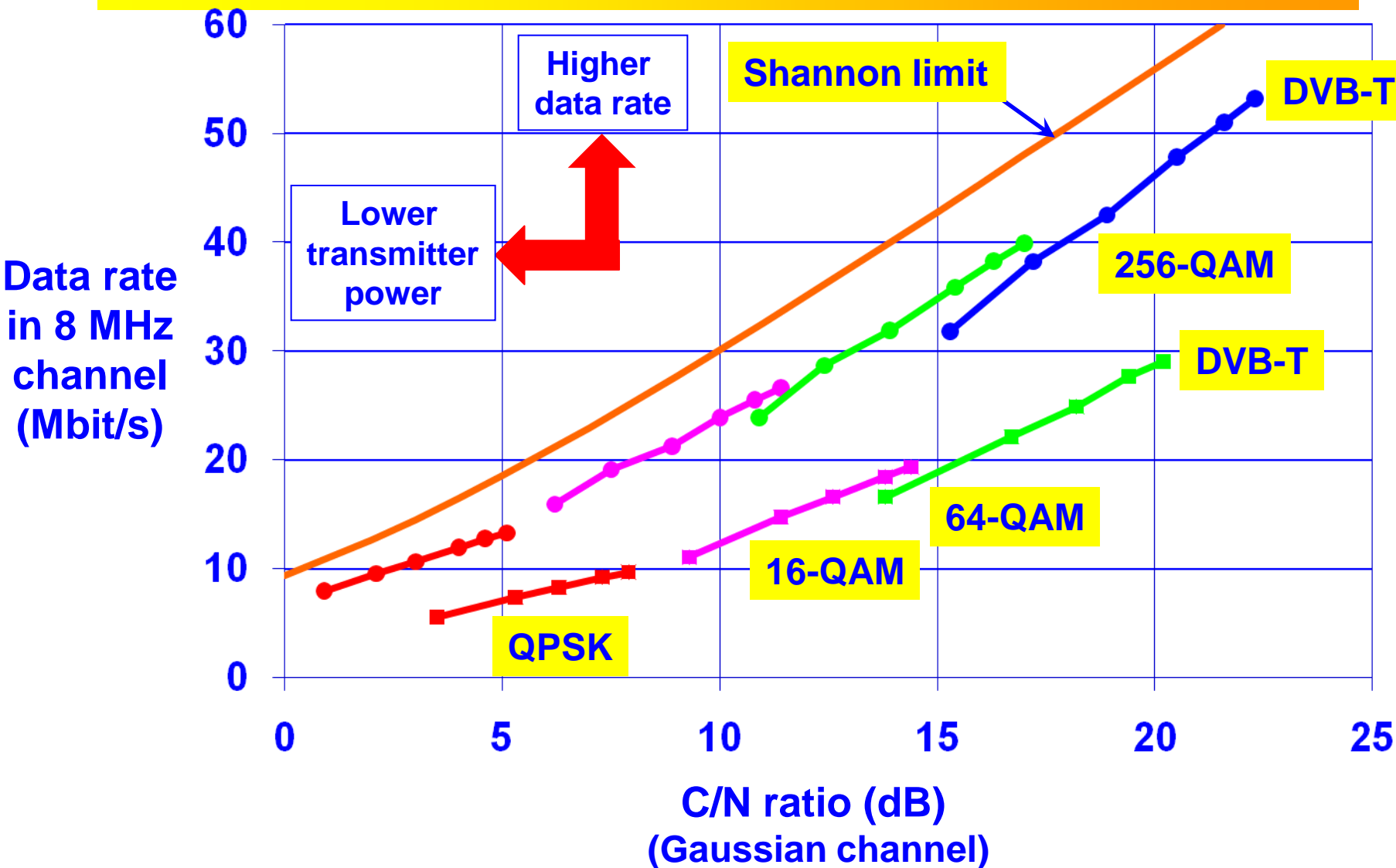

DVB-T data from Table A1 of ETSI EN 300 744 V1.6.1. DVB-T2 data from Table 44 of DVB Blue Book A133.

DVB-T, DVB-T2 and ISDB-T (MHz)

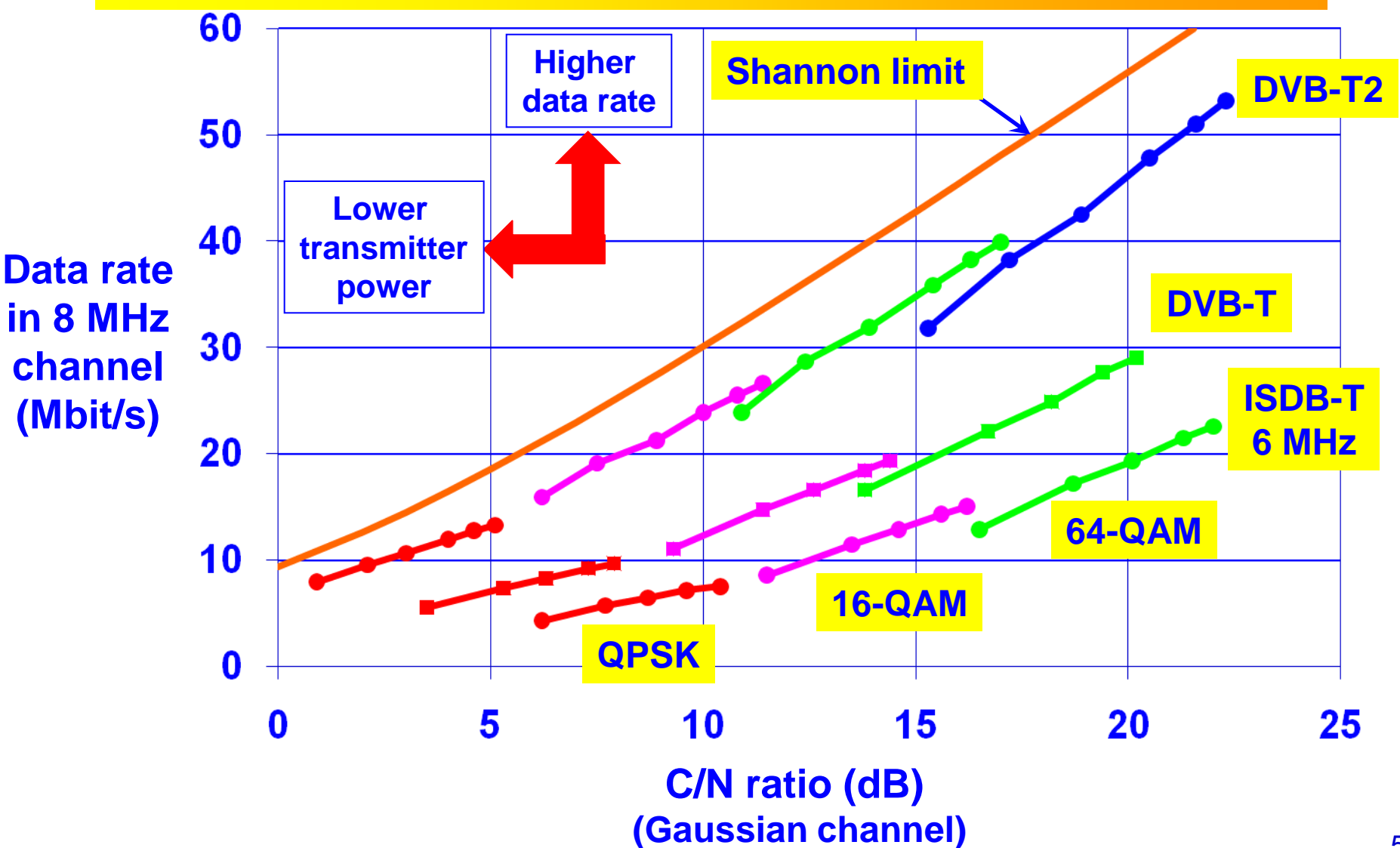

ISDB-T data from Table 3-4 and Table A3.3-2 of ARIB STD-B31 Version 1.6

DVB-T, DVB-T2 and ISDB-T (8 MHz)

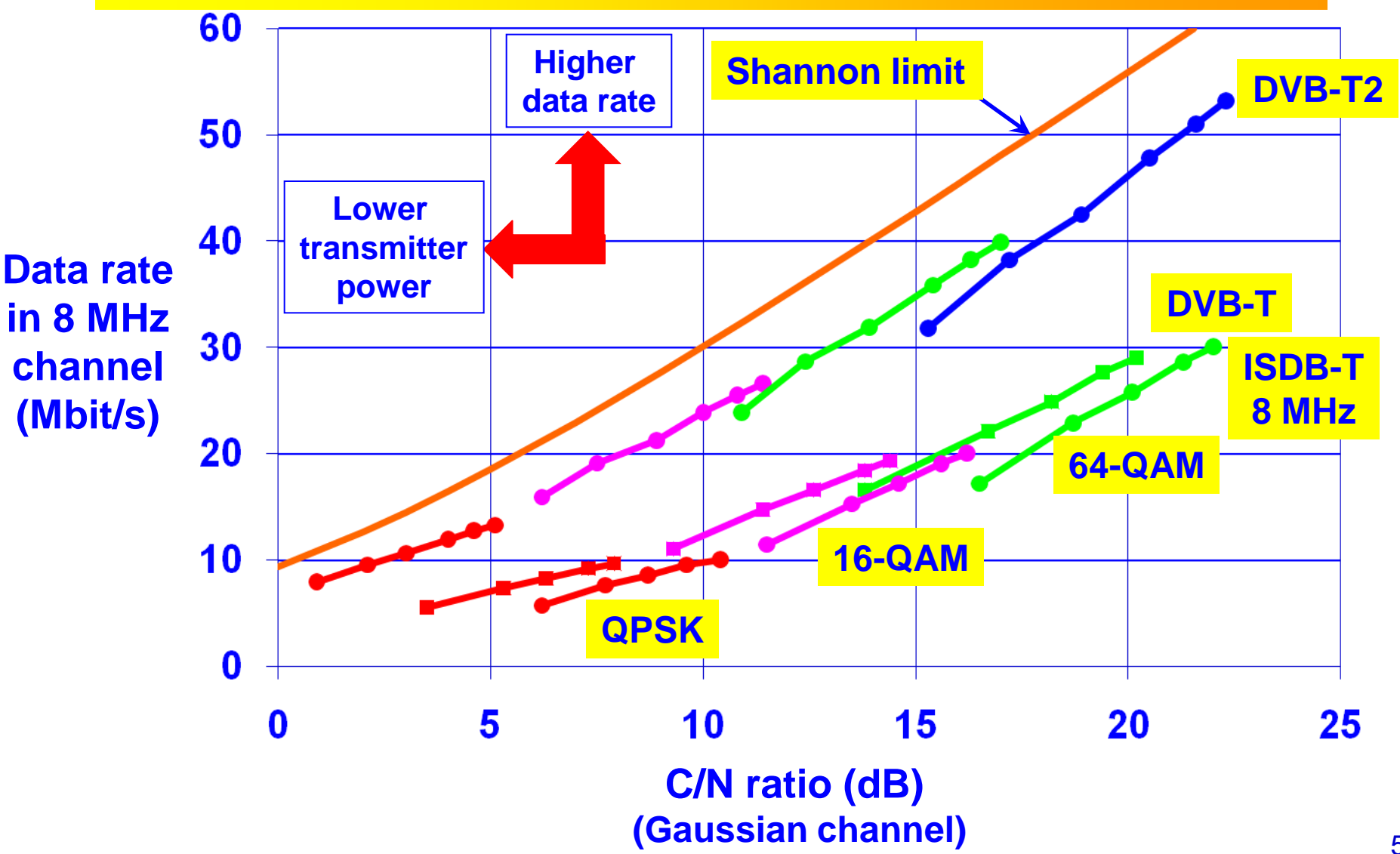

Case Study- DVB-T @ (8 MHz)

DVB-T Reference Mode	
Modulation	64 QAM
Error code rate	3/4
Guard Interval	1/4
FFT	8k
Bit rate (Payload)	22.39 Mbps
C/N required - (Gaussian/Ricean)	(18.2/18.9) dB
Reference TX & Rx systems	
Bandwidth	8 MHz
Notes	
<ul style="list-style-type: none"> •GI = 1/4 Selected to support large SFN operation •Code Rate 3/4 chosen to provide C/N approx 19dB-20dB •Ricean propagation model chosen. 	

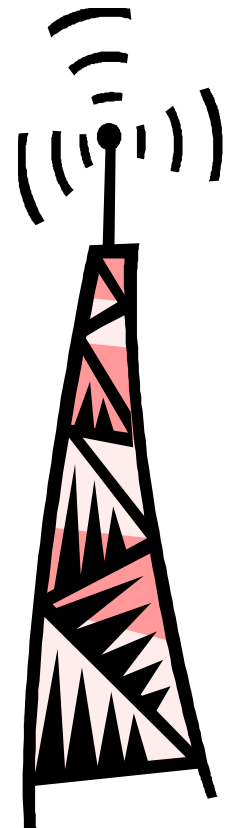

DVB-T Reference mode



Net Capacity in 8 MHz Stationary channels
F1 : Fix Reception - LOS - Rice
(T1 : GI=1/4)

DVB-T

DVB-T Reference ; 64 QAM, 3/4, GI 1/4, C/N 18.9db, 22.39Mb/s

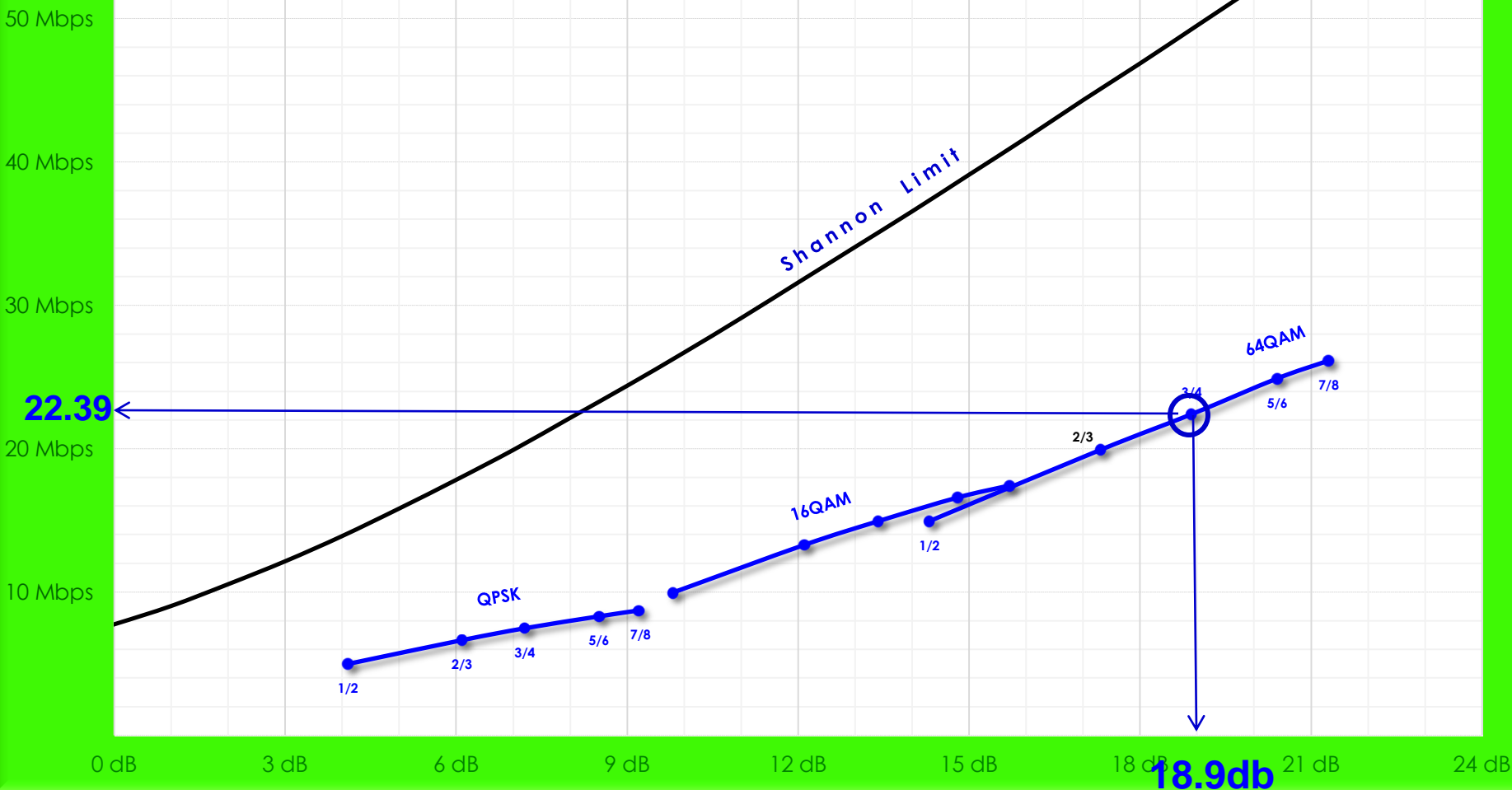

Net Capacity in 8 MHz Stationary channels F1 : Fix Reception - LOS - Rice (T1 : GI=1/4)

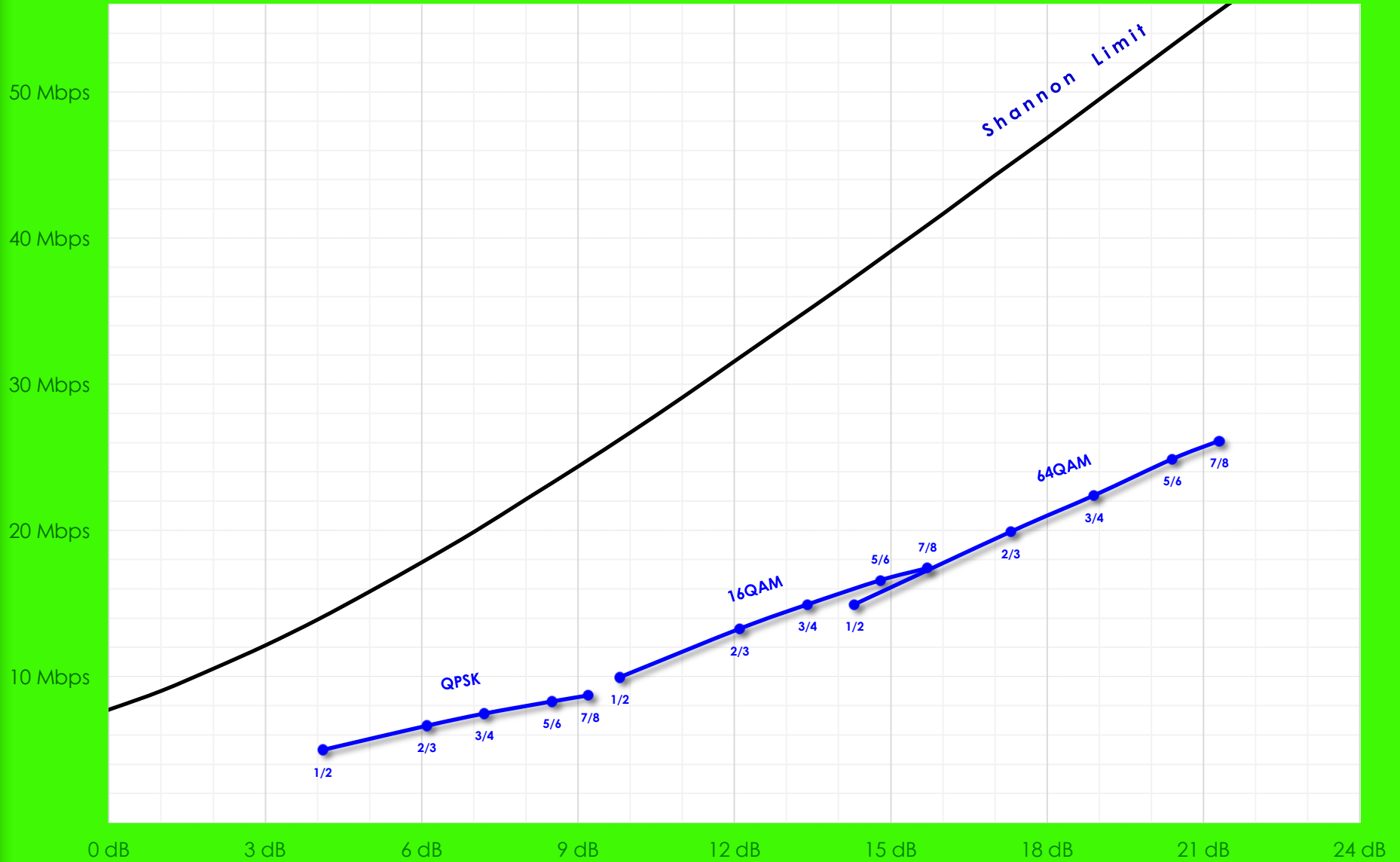

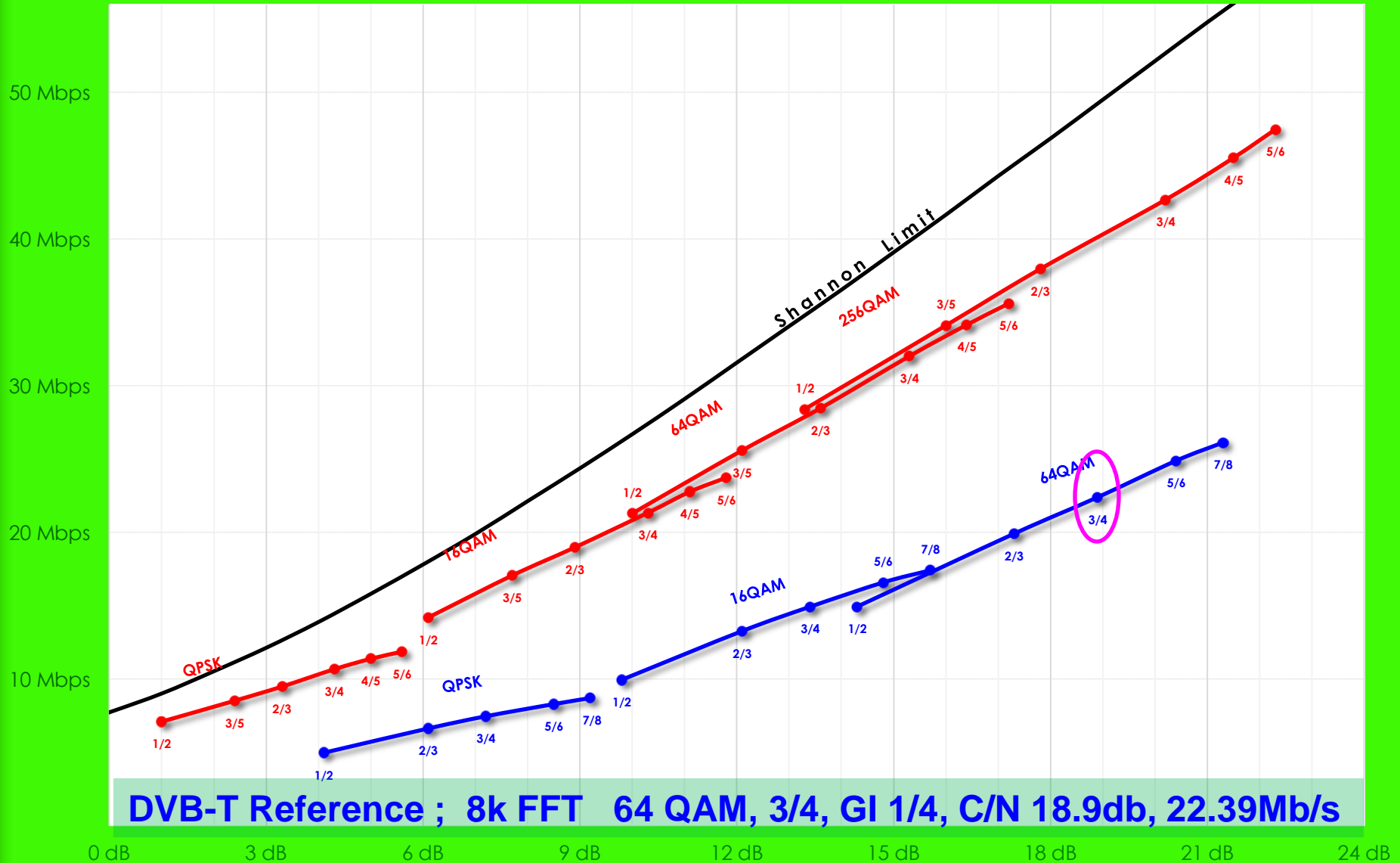

Same Coverage modes

DVB-T2: FFT 32K GI 1/16 (224 μ s) 256 QAM 2/3 (37.95 Mbps) C/N = 17.8 dB (-1.1 dB)

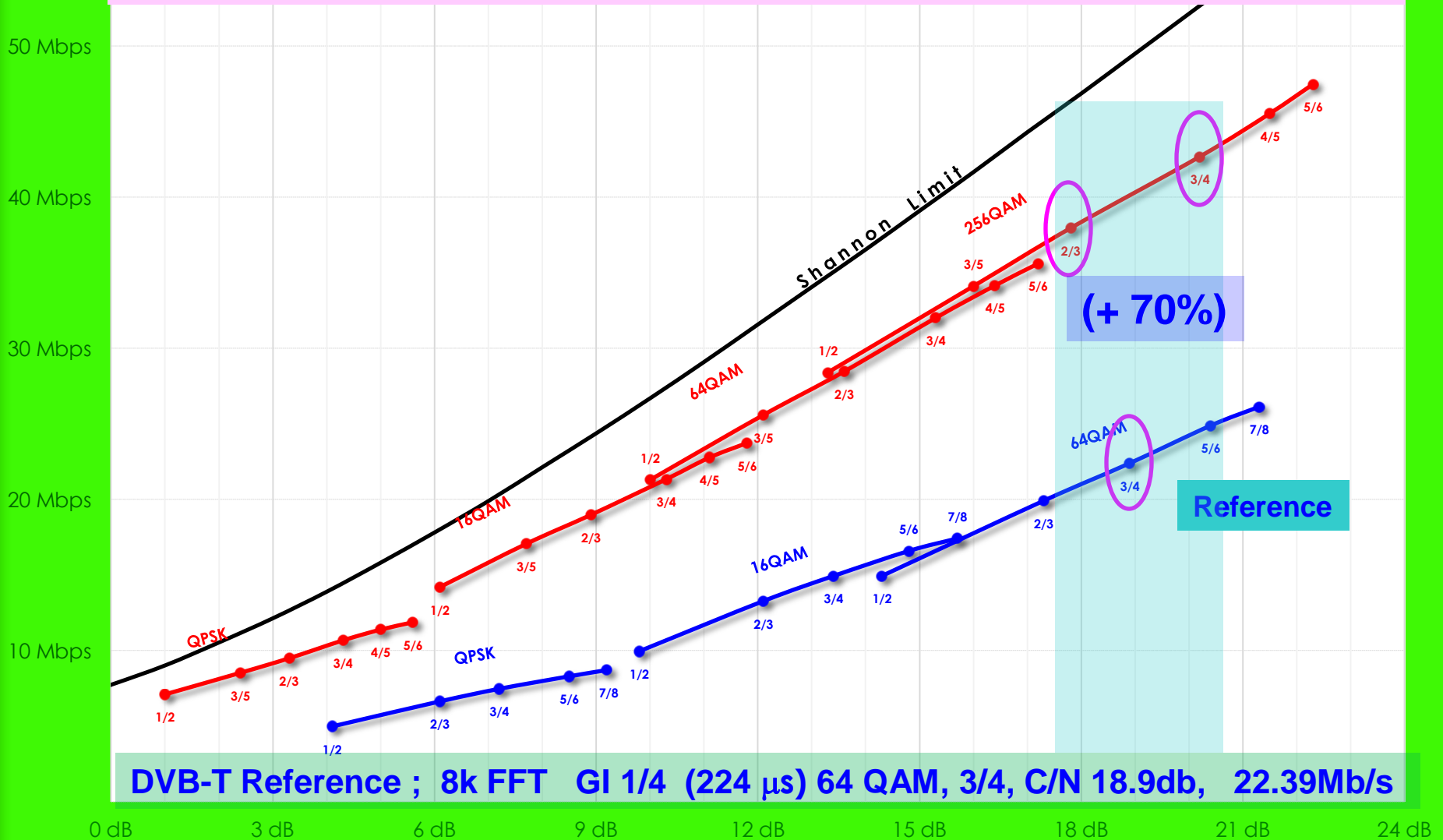

Same Coverage modes

DVB-T2: FFT 32K GI 1/16 (224 μ s) 256 QAM 2/3 (37.95 Mbps) C/N = 17.8 dB (-1.1 dB)
 DVB-T2: FFT 32K GI 1/16 (224 μ s) 256 QAM 3/4 (42.68 Mbps) C/N = 20.2 dB (+1.3 dB)

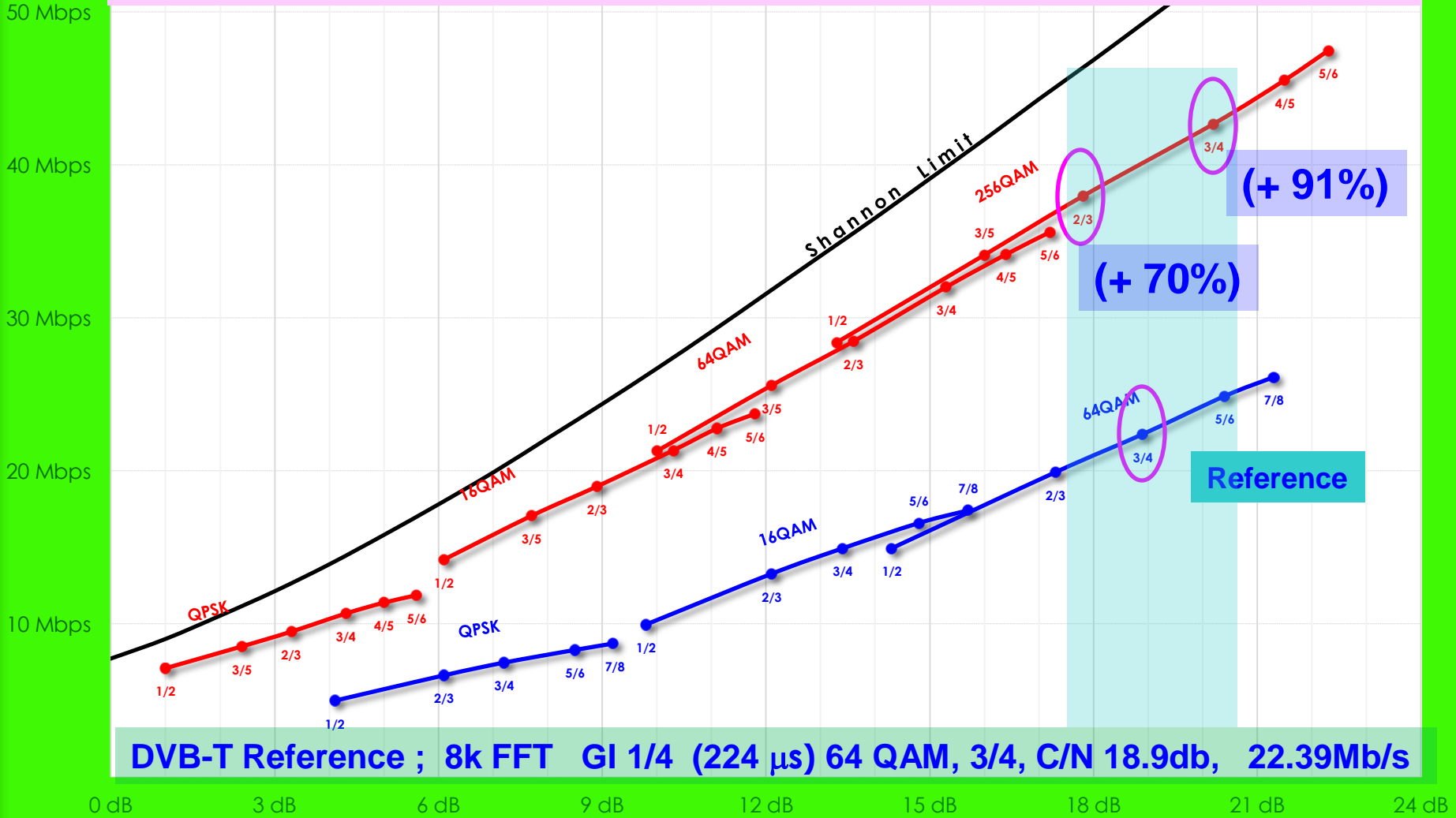

Same Payload modes

DVB-T2: FFT 32K GI 1/16 (224 μs) 16QAM 4/5 (22.70 Mbps) C/N = 11.1 dB (-7.8 dB)

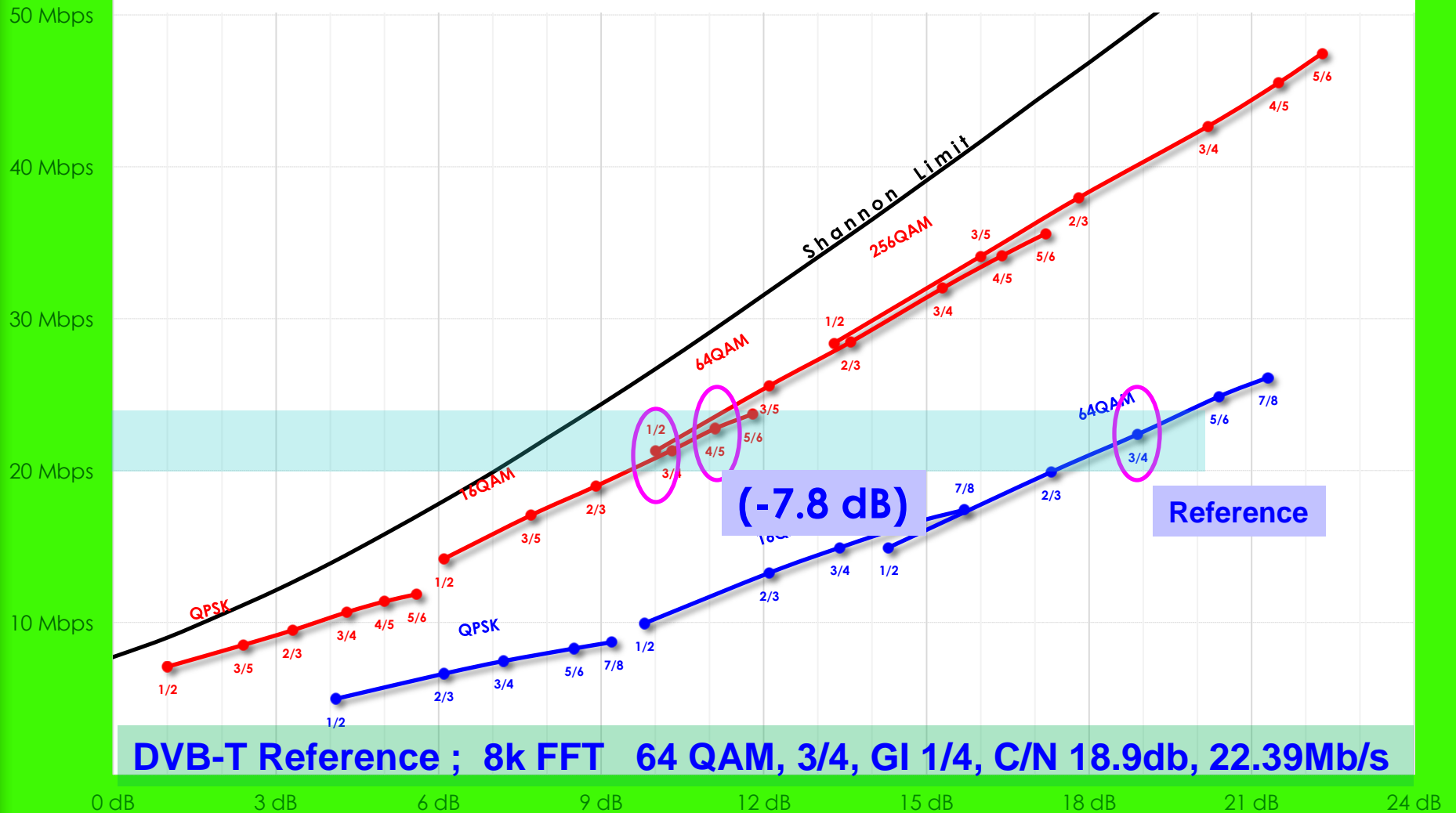

Same Payload modes

DVB-T2: FFT 32K GI 1/16 (224 μs) 16QAM 4/5 (22.70 Mbps) C/N = 11.1 dB (-7.8 dB)
 DVB-T2: FFT 32K GI 1/16 (224μs) 64QAM 1/2 (21.30 Mbps) C/N = 10.0 dB (-8.9 dB)

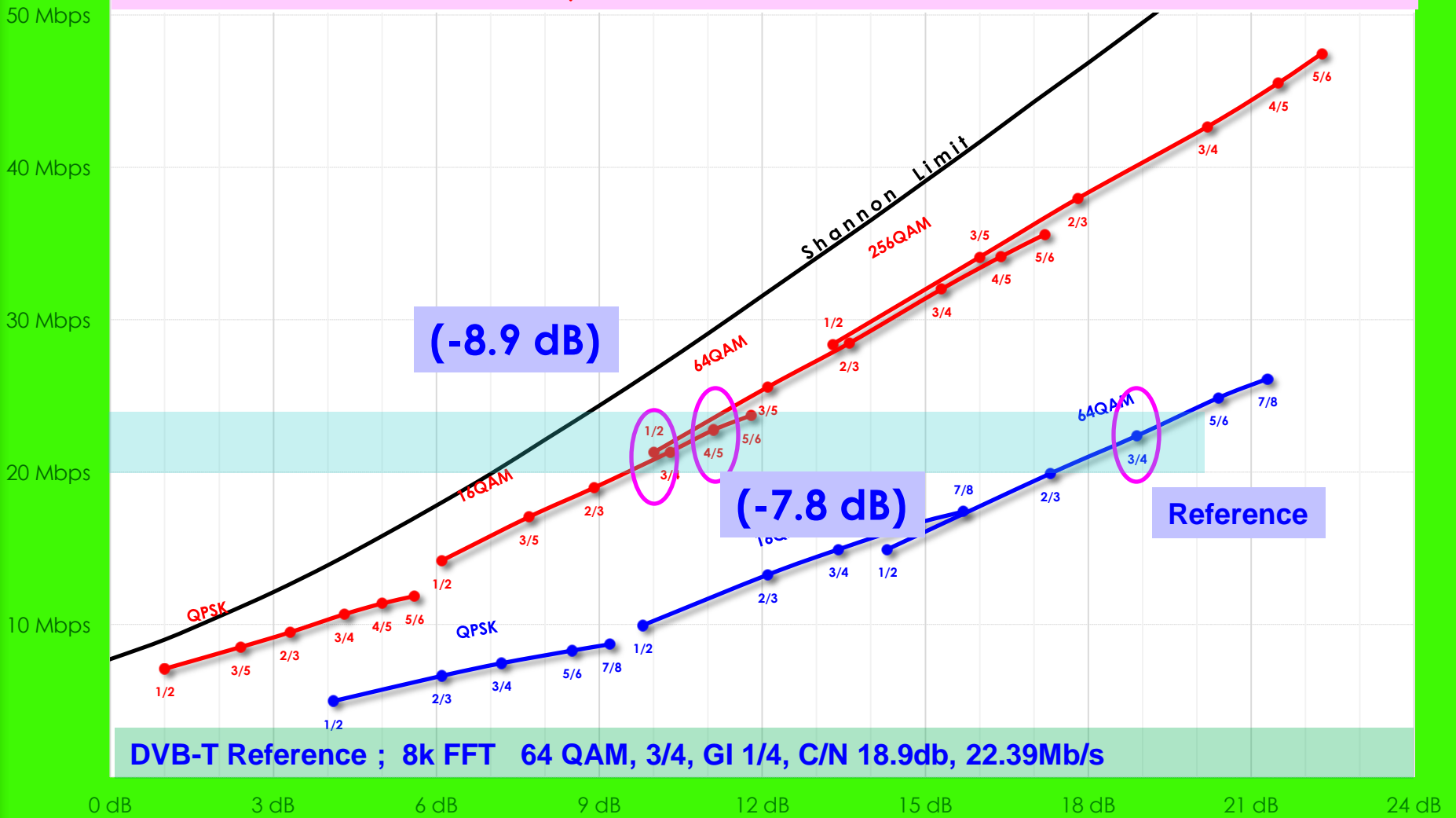

DVB-T Reference ; 8k FFT 64 QAM, 3/4, GI 1/4, C/N 18.9db, 22.39Mb/s



Net Capacity in 8 MHz Stationary channels

F1 : Fix Reception - LOS - Rice

(T2 : GI = 1/16 / T1 : GI = 1/4 / ISDB (8MHz) : GI = 1/4)

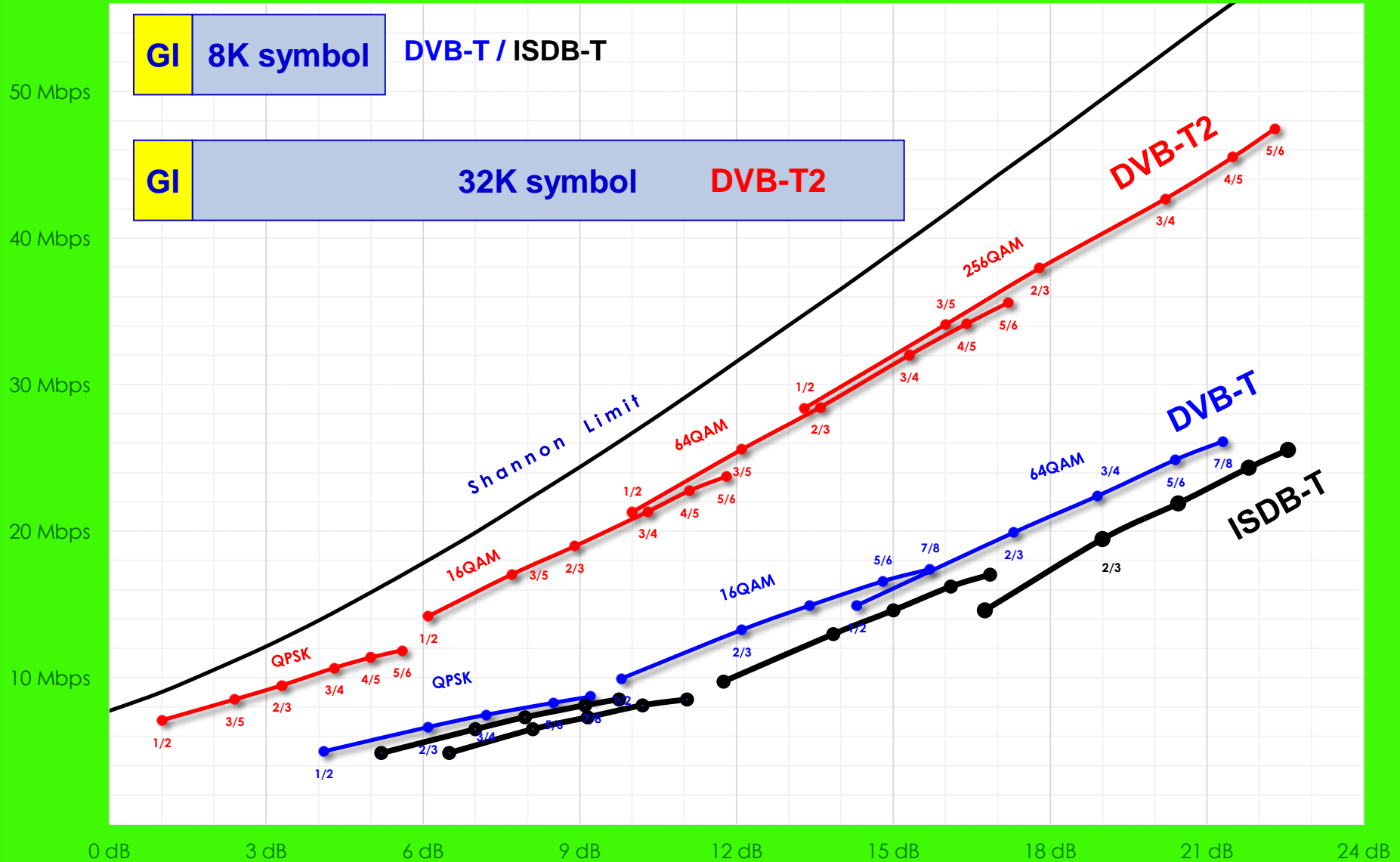

Case Study- ISDB (8 MHz)

ISDB-T Reference Mode	
Modulation (13 Segments)	64 QAM
Error code rate	2/3
Guard Interval	1/4
FFT	8k
Bit rate (Payload)	19.47 Mbps
C/N required - (Gaussian/Ricean)	(18.6/19.3) dB

Reference TX & Rx systems	
Bandwidth	8 MHz

Notes
<ul style="list-style-type: none"> •GI = 1/4 Selected to support large SFN operation •Ricean propagation model chosen. •ISDB Characteristics obtained by normalising 6 MHz data to 8 MHz

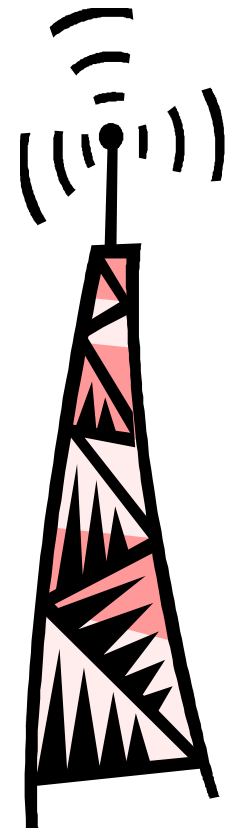

ISDB-T Reference System



Net Capacity in 8MHz Stationary channels
 F1 : Fix Reception - LOS - Rice
 (DVB-T2 : Red / ISDB-T : Blue)

ISDB-T: FFT 8K GI 1/4 (224 μs) 64QAM 2/3 (19.47 Mbps) C/N = 19.3 dB (0.0 dB)

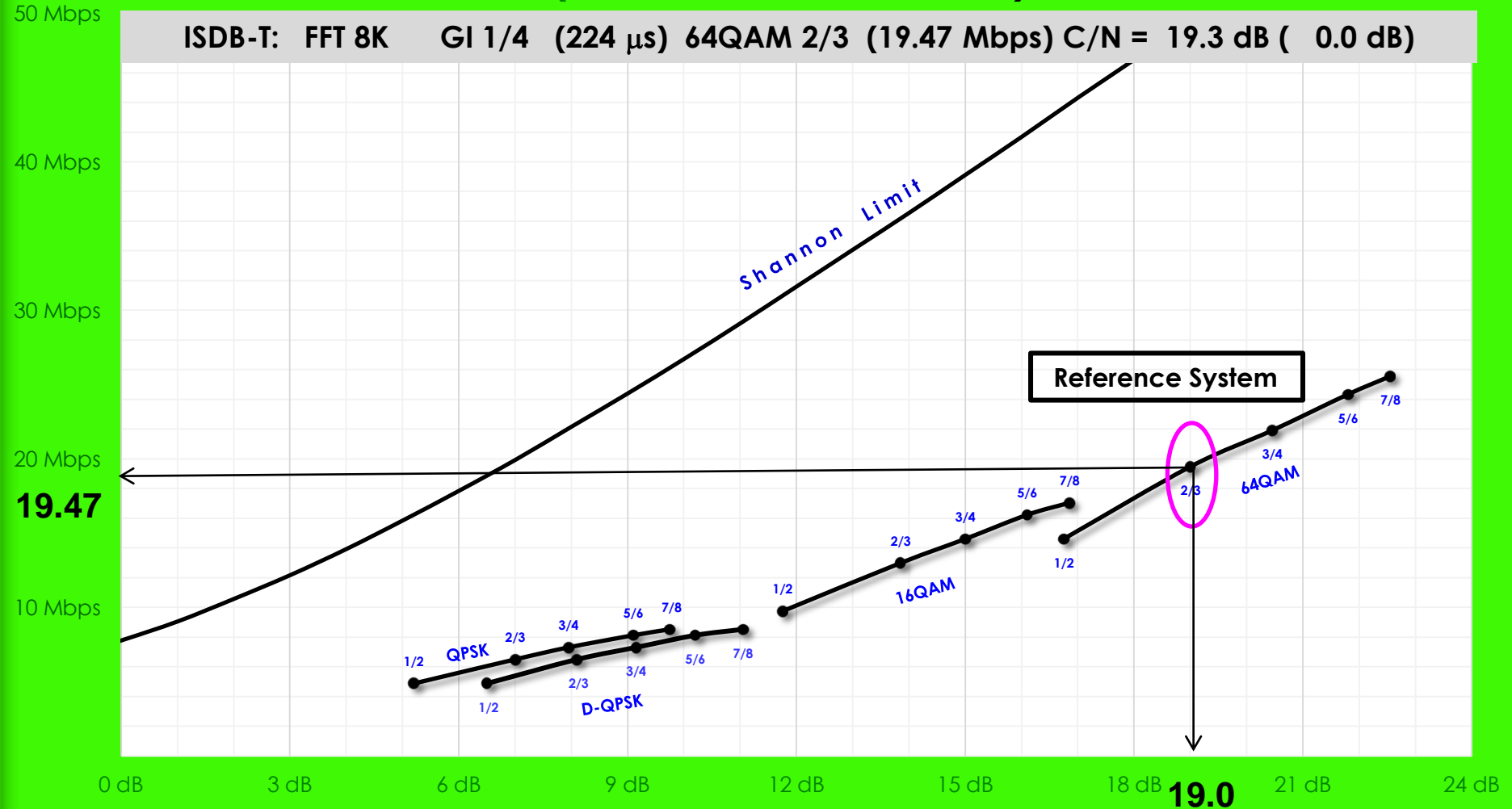

DVB-T2: FFT 32K GI 1/16 (224 μ s) 256QAM 3/4 (42.58 Mbps) C/N = 20.2 dB (+ 1.2 dB)
 DVB-T2: FFT 32K GI 1/16 (224 μ s) 256QAM 2/3 (37.86 Mbps) C/N = 17.8 dB (- 1.2 dB)

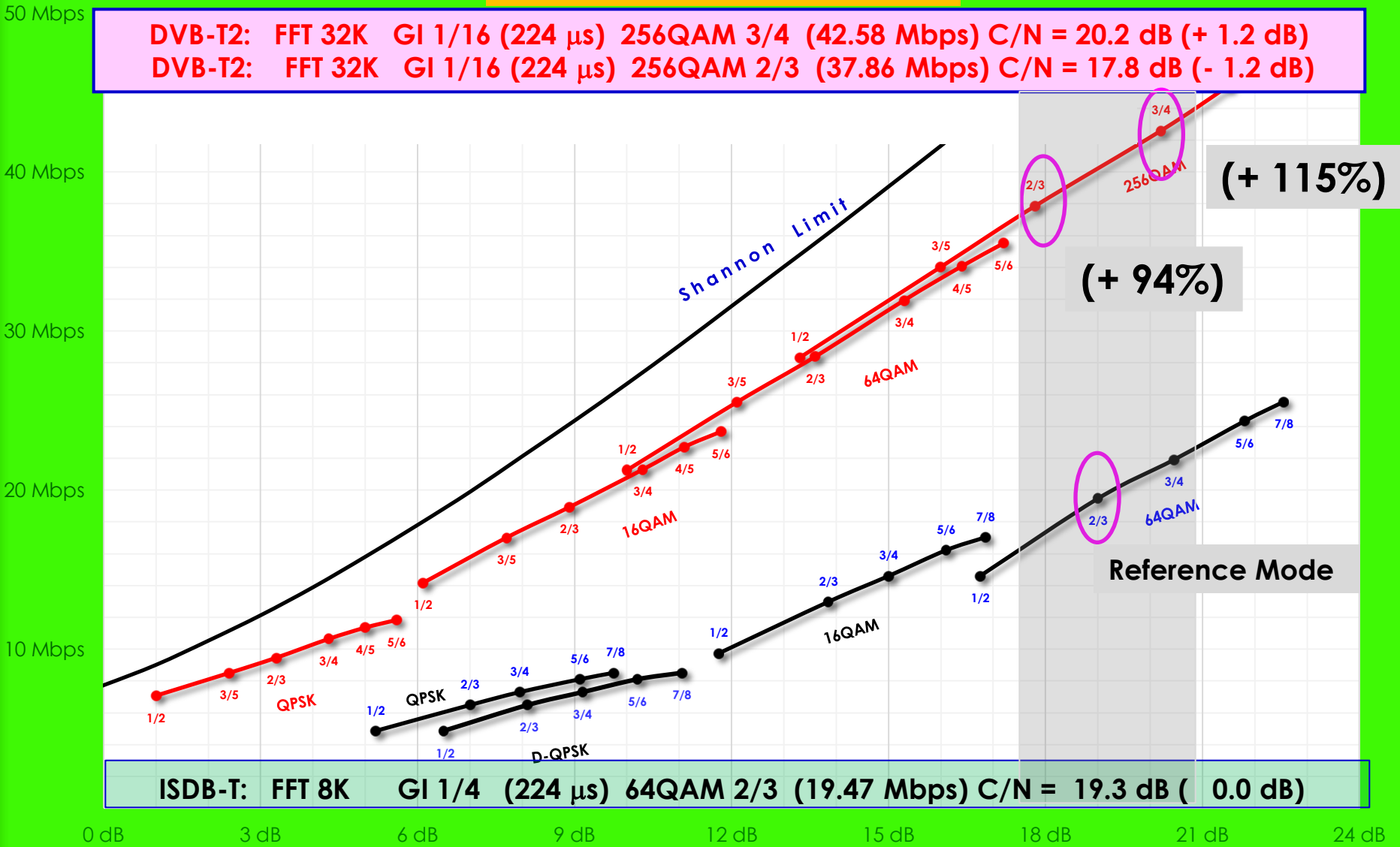

Same Payload modes

DVB-T2: FFT 32K GI 1/16 (224 μs) 16QAM 2/3 (18.93 Mbps) C/N = 8.9 dB (-10.1 dB)
 DVB-T2: FFT 32K GI 1/16 (224 μs) 16QAM 3/4 (21.29 Mbps) C/N = 10.1 dB (-8.9 dB)

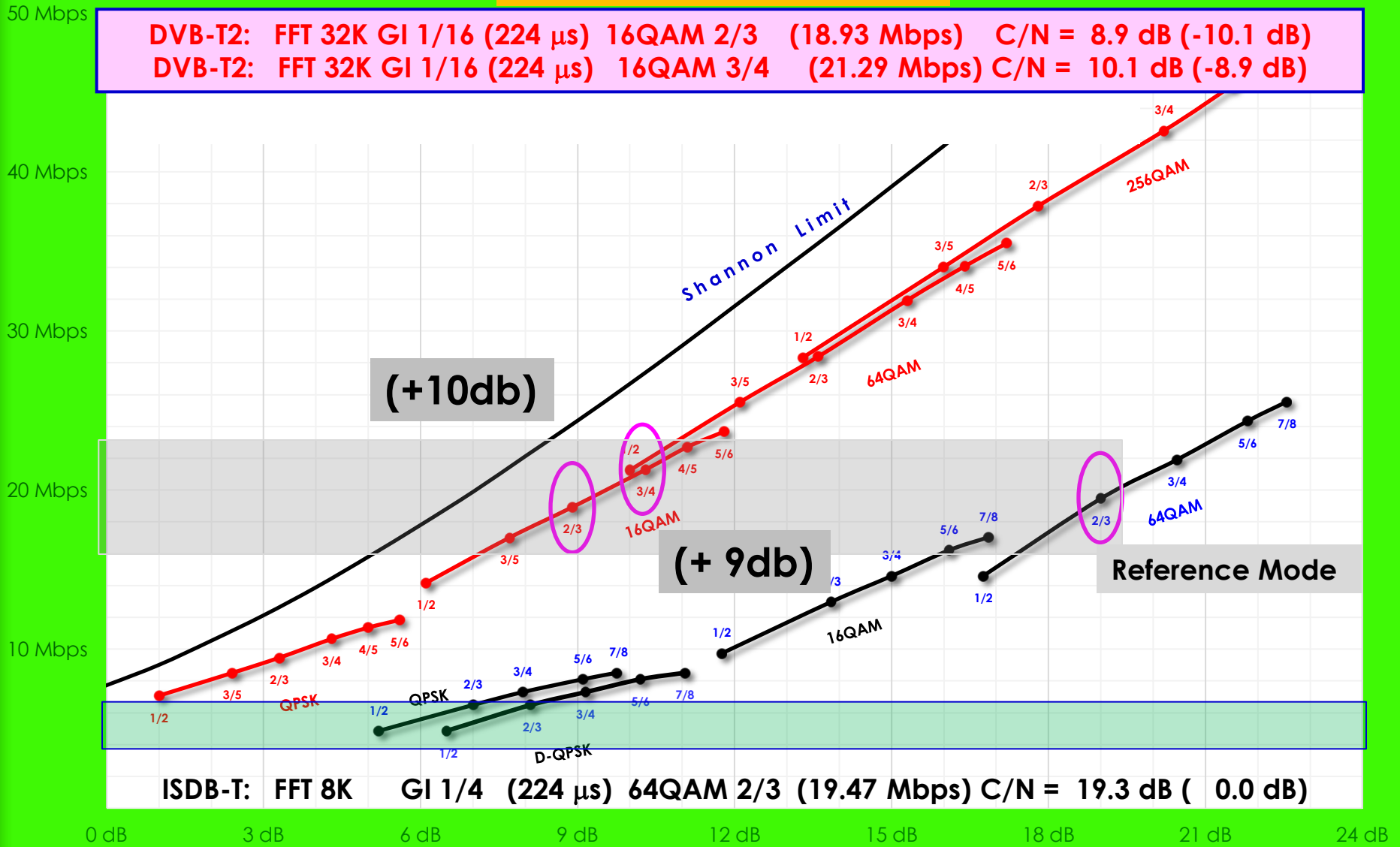

ISDB-T: FFT 8K GI 1/4 (224 μs) 64QAM 2/3 (19.47 Mbps) C/N = 19.3 dB (0.0 dB)

System Comparison DVB-T2 / DVB-T / ISDB-T			Summary
System	Transmission Mode	Data Rate (Payload) Mb/s	C/N Ricean Model dB
DVB-T	64 QAM, GI 1/4, 3/4, 8K	22.39 (ref)	18.9 (0)
DVB-T2	256 QAM, GI 1/16, 2/3, 32k	37.9 (+70%)	17.8
DVB-T2	256 QAM, GI 1/16, 3/4, 32k	42.7 (+91%)	20.2
DVB-T2	16QAM, GI 1/16, 4/5, 32K	22.7	11.1 (-7.8)
DVB-T2	64QAM, GI 1/16, 1/2, 32K	21.3	10.0 (-8.9)
ISDB-T	64 QAM, GI 1/4, 2/3, 8K	19.47 (ref)	19.3(0)
DVB-T2	256 QAM, GI 1/16, 2/3, 32k	37.9 (+94%)	17.8
DVB-T2	256 QAM, GI 1/16, 3/4, 32k	42.7 (+115%)	20.2
DVB-T2	16QAM, GI 1/16, 3/4, 32K	21.29	10.1 (-8.9)
DVB-T2	16QAM, GI 1/16, 2/3, 32K	18.9	8.9 (-10)
Same Coverage			
Same Payload			

DVB-T2 RELATIVE PERFORMANCE

- Compared with DVB-T % ISDB -T 1st Generation standards
 - DVB-T2 can increase significantly the payload capacity for the same coverage (C/N ratio)
 - In the examples the increase ranges 70% - 115%
 - This increase can be translated into more services per RF Channel and increased spectrum productivity.
 - 4 – 6 HDTV services in one RF channel
 - 10 – 16 SDTV services
 - Effective Spectrum saving >70%

OR

- DVB-T2 can with the same payload as ISDB-T or DVB-T
 - Reduction of Transmitter power (same coverage) 1/4 - 1/10
 - Increase the coverage by 6 – 10 db (same Tx power)

Versatility of DVB-T2

Benefits can be realized in different ways

Payload gain:

- Better quality
- More channels
- Less Spectrum

C/N gain:

- Transmission side:
 - Lower power (1/4 – 1/10 power of Tx)
 - Less transmitters/sites
 - High Spectrum saving
- Reception side:
 - extended coverage
 - Better indoor portable/mobile reception
 - lower antenna/receiver gain needed (indoor aerials)

Thank You